



LEXI-R422

Ultra-small LTE-M / NB-IoT / EGPRS module

Data sheet



Abstract

Technical data sheet describing the ultra-small LEXI-R422 modules, a complete and cost-efficient solution offering multi-band LTE-M / NB-IoT / EGPRS data transmissions for low power wide area solutions in the ultra-compact LEXI form factor.

Document information

Title	LEXI-R422	
Subtitle	Ultra-small LTE-M / NB-IoT / EGPRS module	
Document type	Data sheet	
Document number	UBX-22020834	
Revision and date	R03	06-Oct-2023
Disclosure restriction	C1-Public	

Product status	Corresponding content status	
Functional sample	Draft	For functional testing. Revised and supplementary data will be published later.
In development / Prototype	Objective specification	Target values. Revised and supplementary data will be published later.
Engineering sample	Advance information	Data based on early testing. Revised and supplementary data will be published later.
Initial production	Early production information	Data from product verification. Revised and supplementary data may be published later.
Mass production / End of life	Production information	Document contains the final product specification.

This document applies to the following products:

Product name	Type number	Firmware version	Notification reference	Product status
LEXI-R422	LEXI-R422-01B-00	Modem: 01.25 Application: A01.06	UBXDOC-686885345-1805	Engineering sample

u-blox or third parties may hold intellectual property rights in the products, names, logos and designs included in this document. Copying, reproduction, modification or disclosure to third parties of this document or any part thereof is only permitted with the express written permission of u-blox.

The information contained herein is provided "as is" and u-blox assumes no liability for its use. No warranty, either express or implied, is given, including but not limited to, with respect to the accuracy, correctness, reliability and fitness for a particular purpose of the information. This document may be revised by u-blox at any time without notice. For the most recent documents, visit www.u-blox.com.

Copyright © u-blox AG.

Contents

Document information	2
Contents	3
1 Functional description	5
1.1 Overview.....	5
1.2 Product features	5
1.3 Block diagram	6
1.4 Product description	6
1.5 AT command support	7
1.6 Supported features	7
2 Interfaces	9
2.1 Power management	9
2.1.1 Module supply input (VCC)	9
2.1.2 Generic digital interfaces supply output (V_INT)	9
2.2 Antenna interfaces.....	9
2.2.1 Cellular antenna RF interface (ANT).....	9
2.2.2 Cellular antenna detection (ANT_DET).....	9
2.3 System functions.....	9
2.3.1 Module power-on	9
2.3.2 Module power-off.....	10
2.3.3 Module reset	10
2.4 SIM	11
2.4.1 SIM interface	11
2.4.2 SIM detection	11
2.5 Serial communication	11
2.5.1 UART interfaces.....	11
2.5.2 USB interface.....	12
2.5.3 I2C interface.....	12
2.6 GPIO	12
2.7 Cellular antenna dynamic tuner interface	13
2.8 Reserved pin (RSVD)	13
3 Pin definition	14
3.1 Pin assignment.....	14
4 Electrical specifications	20
4.1 Absolute maximum rating.....	20
4.1.1 Maximum ESD.....	20
4.2 Operating conditions.....	21
4.2.1 Operating temperature range.....	21
4.2.2 Supply/power pins	21
4.2.3 Current consumption.....	22
4.2.4 LTE RF characteristics	22

4.2.5	2G RF characteristics	24
4.2.6	ANT_DET pin.....	25
4.2.7	PWR_CTRL pin	25
4.2.8	SIM pins	25
4.2.9	I2C pins	25
4.2.10	Generic Digital Interfaces pins	26
4.2.11	USB pins	26
5	Mechanical specifications	27
6	Qualification and approvals.....	28
6.1	Reliability tests.....	28
6.2	Approvals.....	28
7	Product handling & soldering.....	29
7.1	Packaging	29
7.1.1	Reels	29
7.1.2	Tapes.....	29
7.2	Moisture sensitivity levels.....	29
7.3	ESD precautions.....	30
7.4	Reflow soldering	30
8	Labeling and ordering information	31
8.1	Product labeling.....	31
8.2	Explanation of codes	31
8.3	Ordering information.....	31
Appendix	32
A	Glossary	32
Related documentation	34
Revision history	34
Contact	34

1.3 Block diagram

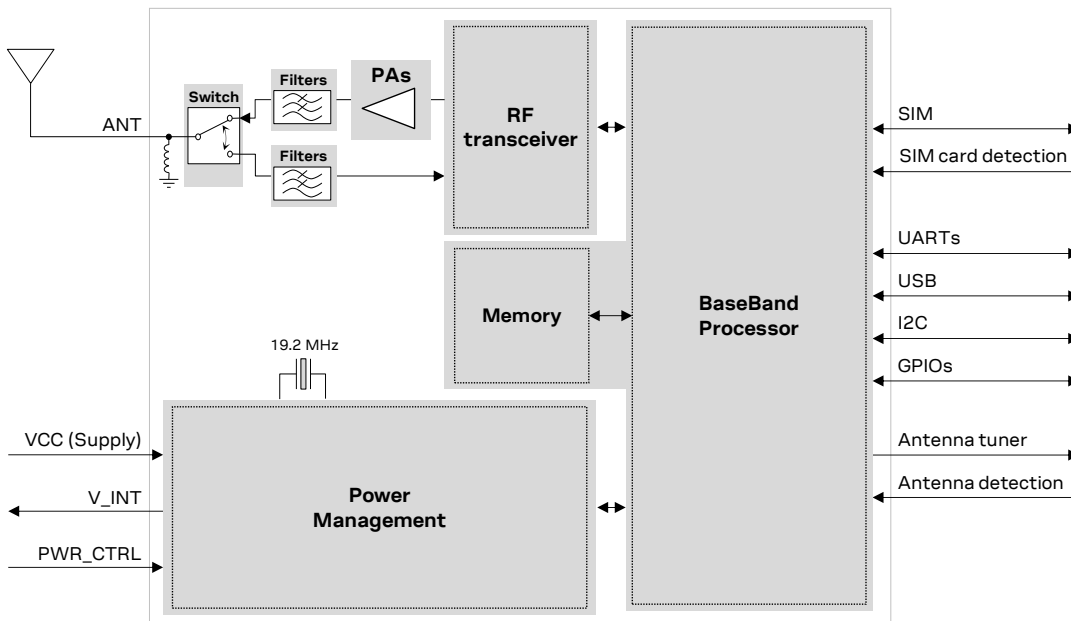

Figure 1: LEXI-R422 block diagram

1.4 Product description

Item	LTE	2G
Protocol stack	3GPP Release 14	3GPP Release 9
Radio Access Technology	LTE Cat M1 Half-Duplex LTE Cat NB2 Half-Duplex	2G GPRS / EGPRS TDMA
Operating bands	LTE FDD band 1 (2100 MHz) LTE FDD band 2 (1900 MHz) LTE FDD band 3 (1800 MHz) LTE FDD band 4 (1700 MHz) LTE FDD band 5 (850 MHz) LTE FDD band 8 (900 MHz) LTE FDD band 12 (700 MHz) LTE FDD band 13 (750 MHz) LTE FDD band 18 (850 MHz) LTE FDD band 19 (850 MHz) LTE FDD band 20 (800 MHz) LTE FDD band 25 (1900 MHz) LTE FDD band 26 (850 MHz) LTE FDD band 28 (700 MHz) LTE FDD band 66 (1700 MHz) LTE FDD band 85 (700 MHz)	GSM 850 MHz E-GSM 900 MHz DCS 1800 MHz PCS 1900 MHz
Power class	LTE category M1 / NB2: Class 3 (23 dBm)	2G GSMK: Class 4 (33 dBm) in 850/900 MHz Class 1 (30 dBm) in 1800/1900 MHz 2G 8-PSK: Class E2 (27 dBm) in 850/900 MHz, Class E2 (26 dBm) in 1800/1900 MHz
Data rate	LTE category M1: up to 1200 kbit/s UL, up to 375 kbit/s DL LTE category NB2: up to 140 kbit/s UL, up to 125 kbit/s DL	GPRS multi-slot class 33: up to 85.6 kb/s UL, up to 107 kb/s DL EGPRS multi-slot class 33: up to 236.8 kb/s UL, up to 296 kb/s DL

Table 2: LEXI-R422 cellular main characteristics

1.5 AT command support

The LEXI-R422 module supports AT commands according to the 3GPP standards TS 27.007 [4], TS 27.005 [5], TS 27.010 [6], and the u-blox AT commands extension.

 For the complete list of AT commands and their description, see the AT commands manual [1].

1.6 Supported features

Table 3 lists some of the main features supported by LEXI-R422 modules.

Feature	Description
Device security	Hardware-based security functions of the chipset are used to provide: <ul style="list-style-type: none"> Secure boot: guarantees software authenticity and integrity Secure update: supervise the secure delivery of the correct FW to the module Secure production: secret keys are programmed into the module using encrypted protocols and within u-blox secured manufacturing environment.
MQTT Anywhere, MQTT Flex	With u-blox's communication services – MQTT Anywhere or MQTT Flex – data overhead, time spent on-the-air, and energy consumption can be reduced, thus enabling users to extend device life cycles, lower costs, and improve ROI.
External GNSS control via modem	Access to external u-blox positioning chips and modules through I2C interface. This means that any host processor can control the LEXI-R422 module and the u-blox positioning chip or module through a single serial port.
Embedded AssistNow Software	Embedded AssistNow Online and AssistNow Offline clients are available.
CellLocate®	Enables the estimation of device position based on the parameters of the mobile network cells visible to the specific device based on the CellLocate® database.
Hybrid positioning	Provides the module's current position using the GNSS position or the estimated position from CellLocate®, depending on which positioning method provides the best and fastest solution according to the user configuration.
Antenna dynamic tuning	Real-time control of an external antenna matching IC via two dedicated pins of the module according to the LTE band used by the module, configurable by dedicated AT command.
Embedded TCP and UDP stack	Embedded TCP/IP and UDP/IP stack including direct link mode for TCP and UDP sockets. Sockets can be set in Direct Link mode to establish a transparent end-to-end communication with an already connected TCP or UDP socket via the serial interface.
HTTP, HTTPS (v1.0 for +UHTTP, v1.1 for LwM2M client)	Hyper-Text Transfer Protocol as well as Secure Hyper-Text Transfer Protocol (SSL encryption) functionalities are supported via AT commands.
FTP, FTPS	File Transfer Protocol as well as Secure File Transfer Protocol (SSL encryption of FTP control channel) functionalities are supported by AT commands.
CoAP (RFC 7252 [12])	Embedded Constrained Application Protocol (CoAP) datagram-based client/server application protocol designed to easily translate from HTTP for simplified integration with the web.
MQTT (v3.1.1) and MQTT-SN (v1.2)	Embedded Message Queuing Telemetry Transport (MQTT) and MQTT for Sensor Networks (MQTT-SN) publish-subscribe messaging protocols designed for lightweight M2M communications over TCP (MQTT) or over UDP (MQTT-SN). These allow one-to-one, one-to-many and many-to-one communications over a TCP or UDP connection.
LwM2M with dynamically loaded objects (v1.0)	The LwM2M is a light and compact communication protocol designed for managing IoT machine-to-machine communication between a LwM2M server and a LwM2M client located in lightweight, low power or resource-constrained LwM2M devices, with object data model. LEXI-R422 modules allow customers to configure dynamically loaded run time objects, defining necessary custom objects, creating instances of those objects as appropriate, managing module LwM2M protocol stack to interact with the LwM2M server.
TLS (v1.0, v1.1, v1.2, v1.3) and DTLS (v1.2)	Transport Layer Security (TLS) version 1.3 provides security for HTTP, FTP, MQTT and TCP communications. Embedded Datagram Transport Layer Security (DTLS) version 1.2 provides security for CoAP, LwM2M, MQTT-SN and UDP communications.

Feature	Description
Jamming detection	Detects “artificial” interference that obscures the operator’s carrier entitled to give access to the radio service and automatically reports the start and stop of such conditions to the application processor that can react accordingly.
Last gasp	In case of power supply outage the cellular module can be configured through the +ULGASP AT command to send an alarm notification to a remote entity.
Network indication	GPIO configured to indicate the network status: registered home network, registered roaming, data call enabled, no service. The feature can be enabled through the +UGPIOC AT command.
Antenna detection	The ANT_DET pin provides antenna presence detection capability, evaluating the resistance from the ANT pin to GND by an external antenna detection circuit implemented on the application board. The feature can be enabled through the +UANTR AT command.
BIP	Bearer Independent Protocol for over-the-air SIM provisioning.
Dual stack IPv4/IPv6	Capability to move between Ipv4 and dual stack network infrastructures. IPv4 and IPv6 addresses can be used.
Firmware update Over AT commands (FOAT)	Firmware module update over AT command interface.
Firmware update Over The Air (FOTA)	Firmware module update over the LTE air interface using FTP /HTTP.
u-blox Firmware update Over The Air (uFOTA)	u-blox firmware module update over the LTE air interface client/server solution using LwM2M.
Power Saving Mode (PSM)	The Power Saving Mode (PSM) feature, defined in 3GPP Rel.13, allows further reduction of the module current consumption maximizing the amount of time a device can remain in PSM low power deep-sleep mode during periods of data inactivity.
eDRX	Extended mode DRX, based on 3GPP Rel.13, reduces the amount of signaling overhead decreasing the frequency of scheduled measurements and/or transmissions performed by the module in idle mode. This in turn leads to a reduction in the module power consumption while maintaining a perpetual connection with the base station.
Coverage Enhancement	Coverage Enhancement (CE) mode introduced in 3GPP Rel.13 are used to improve the cell signal penetration.
Connected Mode Mobility	LTE Cat M1 Connected Mode Mobility (CMM) with CE Mode A
Release Assistance Indicator	The 3GPP Release Assistance feature allows the module to request for the Radio Resource Control connection to be dropped as soon as the message has been received by the network. This feature allows a reduction in the module power consumption.
Backup and restore	This feature allows the modules to autonomously restore the flash file system using the last backup stored on the module itself. For further details about the backup and restore feature, see the +UBKUPDATA AT command description in the AT commands manual [1]

Table 3 Main features supported by LEXI-R422 modules

 u-blox is extremely mindful of user privacy. When a position is sent to the CellLocate® server, u-blox is unable to track the SIM used or the specific device.

2 Interfaces

2.1 Power management

2.1.1 Module supply input (VCC)

LEXI-R422 modules must be supplied through the **VCC** pins by a proper external DC power supply providing a nominal voltage within the normal operating range (see [Table 10](#)). Voltage must be stable, because during operation the current drawn from **VCC** may vary significantly, based on the power consumption profile of the LTE-M, NB-IoT and the 2G radio access technologies described in the LEXI-R422 system integration manual [\[2\]](#).

LEXI-R422 modules provide separate supply inputs over the three **VCC** pins:

- **VCC** pins A13 and A14 (number 41 and 40) are the supply input for the internal RF Power Amplifier, demanding most of the total current drawn of the module when RF transmission is enabled
- **VCC** pin A12 (number 42) is the supply input for the internal baseband Power Management Unit, demanding minor part of the total current drawn of the module when RF transmission is enabled

The internal baseband Power Management Unit integrates voltage regulators generating all the internal supply voltages needed by the module for its intended operations. This includes the supply voltage for the generic digital interfaces (**V_INT**) and for the SIM interface (**VSIM**).

It is important that the system power supply circuit can withstand the maximum pulse current during a transmit burst at maximum power level (see [Table 12](#)).

2.1.2 Generic digital interfaces supply output (V_INT)

LEXI-R422 modules provide a 1.8 V supply rail output on the **V_INT** pin, which is internally generated when the module is switched on, outside the ultra-low power deep-sleep mode. The same voltage domain is used internally to supply the generic digital interfaces of the module. The **V_INT** supply output can be used in place of an external discrete regulator.



It is recommended to provide accessible test points directly connected to the **V_INT** pin.

2.2 Antenna interfaces

2.2.1 Cellular antenna RF interface (ANT)

The **ANT** pin is the cellular RF antenna I/O interface, designed with 50 Ω characteristic impedance.

2.2.2 Cellular antenna detection (ANT_DET)

The **ANT_DET** pin is an analog to digital converter (ADC) input with a current source provided by the LEXI-R422 modules to sense the presence of the external cellular antenna (as an optional feature), evaluating the DC resistance to GND by an externally implemented circuit. For more details, see the LEXI-R422 system integration manual [\[2\]](#) and the AT commands manual [\[1\]](#).

2.3 System functions

2.3.1 Module power-on

When the LEXI-R422 modules are not powered, they can be switched on as following:

- Applying a voltage at the **VCC** module supply input within the operating range (see [Table 10](#)), and then forcing a low level at the **PWR_CTRL** input pin, which is normally set high by an internal pull-up, for a valid time period (see section [4.2.7](#), module switch on).

When the modules are in power-off mode (i.e. switched off, but with a valid voltage present at the **VCC** supply input within the operating range reported in [Table 10](#)), they can be switched on as follows:

- Forcing a low level at the **PWR_CTRL** input pin, which is normally set high by an internal pull-up, for a valid time period (see section [4.2.7](#), module switch on).

When the modules are in low power PSM / eDRX deep-sleep mode, with a valid voltage present at the **VCC** supply input within the operating range reported in [Table 10](#), they can be woken up as follows:

- Forcing a low level at the **PWR_CTRL** input pin, which is normally set high by an internal pull-up, for a valid time period (see section [4.2.7](#), module wake-up from PSM / eDRX deep-sleep).

The **PWR_CTRL** line is intended to be driven by open drain, open collector or contact switch.



It is recommended to provide accessible test points directly connected to the **PWR_CTRL** pin.

2.3.2 Module power-off

The proper graceful power-off procedure of the LEXI-R422 modules, with storage of the current parameter settings in module's non-volatile memory and a clean network detach, can be triggered by:

- AT+CPWROFF command (see the AT commands manual [\[1\]](#))
- Forcing a low pulse at the **PWR_CTRL** input pin, for a valid time period (see section [4.2.7](#), module graceful switch-off)

A faster emergency power-off procedure of LEXI-R422, with storage of current parameter settings in the module's non-volatile memory, but without a clean network detach, can be triggered by:

- AT+CFUN=10 command (see the AT commands manual [\[1\]](#))
- Forcing a rising edge at the GPIO input pin configured with the faster power-off function (see section [2.6](#), faster power-off)

The fastest memory-safe emergency power-off procedure of LEXI-R422, inhibiting further operations in the non-volatile flash memory, without executing the storage of the current parameter settings, and without executing a clean network detach, can be triggered by:

- AT+CFUN=11 command (see the AT commands manual [\[1\]](#))
- Forcing a rising edge at the GPIO input pin configured with the memory-safe power-off function (see section [2.6](#), memory-safe power-off)

An abrupt under-voltage shutdown occurs on the LEXI-R422 when the **VCC** voltage supply is removed. If this event occurs, it is not possible to store the current parameter settings in the module's non-volatile memory or to perform a clean network detach.

LEXI-R422 modules automatically switch off, with storage of the current parameter settings in the module's internal non-volatile memory and a clean network detach, after having sent the last gasp, once the feature is enabled and triggered by the +ULGASP AT command.

2.3.3 Module reset

LEXI-R422 modules can be reset (rebooted), performing storage of the current parameter settings in module's non-volatile memory and a clean network detach before the reboot, by:

- AT+CFUN=16 command (see the AT commands manual [\[1\]](#)).

An abrupt emergency reset (reboot) is triggered on LEXI-R422 modules, without storage of current parameter settings and without a clean network detach, when:

- A low level is applied on the **PWR_CTRL** pin for a valid time period (see section [4.2.7](#), module abrupt emergency reset / reboot).

2.4 SIM

2.4.1 SIM interface

LEXI-R422 modules provide an interface on the **VSIM**, **SIM_IO**, **SIM_CLK**, **SIM_RST** pins to connect an external SIM card/chip. Only the 1.8 V SIM card/chip types are supported. Activation and deactivation are implemented according to the ISO-IEC 7816-3 specifications.

2.4.2 SIM detection

The **GPIO6** pin of LEXI-R422 modules is a 1.8 V digital input which can be configured as an external interrupt to detect the SIM card presence (as a feature which can be optionally used), as intended to be properly connected to the mechanical switch of an external SIM card holder.

For more details see the LEXI-R422 system integration manual [2] and the AT commands manual [1], +UGPIOC, +CIND, +CMER, and +UDCFONF=50 AT commands.

2.5 Serial communication

The LEXI-R422 module provides the following serial communication interfaces:

- UART interfaces, for communications with host application processor (section 2.5.1)
- USB 2.0 interface, for FW update and/or diagnostics only (section 2.5.2)
- I2C bus compatible interface, for communications with external I2C devices (section 2.5.3)

2.5.1 UART interfaces

LEXI-R422 modules include a primary UART interface (UART) for communication with an application host processor, supporting AT commands, data communication, multiplexer protocol functionality, FW update by FOAT, with settings configurable by dedicated AT commands

- 8-wire serial port with RS-232 functionality conforming to ITU-T V.24 recommendation [9], with CMOS compatible signal levels (0 V for low data bit / ON state, 1.8 V for high data bit / OFF state)
 - Data lines (**RXD** as data output, **TXD** as data input)
 - HW flow control lines (**CTS** as flow control output, **RTS** as flow control input)
 - Modem status and control lines (**DTR** input, **DSR** output, **DCD** output, **RI** output)¹
- The default baud rate is 115200 b/s
- The default frame format is 8N1 (8 data bits, no parity, 1 stop bit)

 The UART is available only if the USB is not enabled as an AT command / data communication interface: UART and USB cannot be concurrently used for this purpose.

LEXI-R422 modules include a second auxiliary UART interface (UART AUX) for communication with an application host processor, supporting AT commands, data, GNSS tunneling, FW update by FOAT, with settings configurable by dedicated AT commands

- 4-wire serial port with RS-232 functionality conforming to ITU-T V.24 recommendation [9], with CMOS compatible signal levels (0 V for low data bit / ON state, 1.8 V for high data bit / OFF state)
 - Data lines (**DCD** as data output, **DTR** as data input)
 - HW flow control lines (**RI** as flow control output, **DSR** as flow control input)
- The default baud rate is 115200 b/s
- The default frame format is 8N1 (8 data bits, no parity, 1 stop bit)

¹ **DTR**, **DSR**, **DCD** and **RI** pins can be alternatively configured, in a mutually exclusive way, as secondary auxiliary UART interface.

2.5.1.1 Multiplexer protocol

LEXI-R422 modules include multiplexer functionality as per 3GPP TS 27.010 [6] on the primary UART interface physical link. This is a data link protocol using HDLC-like framing between the module (DCE) and the application processor (DTE), allowing simultaneous sessions over the primary UART.

2.5.2 USB interface

LEXI-R422 modules include a USB 2.0 interface [10], acting as USB device, with the following lines:

- The **USB_D+** / **USB_D-** lines, carrying the USB data and signaling
- The **USB_5V0** input pin to enable the USB interface by applying an external voltage (5.0 V typical)
- The **USB_3V3** input pin to supply the USB interface by applying an external 3.3 V typical voltage

The USB interface is available for FW upgrade by u-blox EasyFlash tool and for diagnostic purposes only: AT commands and data communication are not supported via USB interface.

 It is highly recommended to provide accessible test points directly connected to the USB interface pins (**USB_5V0**, **USB_3V3**, **USB_D+**, **USB_D-**), as well as to the **V_INT**, **PWR_CTRL**, **RSVD #99** pins, for FW update and for diagnostic purposes.

2.5.3 I2C interface

LEXI-R422 modules include a 1.8V I2C-bus compatible interface over the **SDA** and **SCL** pins, available to communicate with an external u-blox GNSS receiver and/or with compatible external I2C devices: the LEXI-R422 module acts as an I2C host that can communicate with I2C devices in accordance with the I2C bus specifications [11].

2.6 GPIO

LEXI-R422 modules include pins that can be configured as general-purpose input/output or to provide custom functions as summarized in Table 4. For further details, see LEXI-R422 system integration manual [2] and the GPIO section of the AT commands manual [1].

Function	Description	Default GPIO	Configurable GPIOs
General purpose output	Output to set the high or the low digital level	--	GPIO1, GPIO2, GPIO3, GPIO4, GPIO5, GPIO6, RFCTRL1, RFCTRL2
General purpose input	Input to sense high or low digital level	RFCTRL1, RFCTRL2	GPIO1, GPIO2, GPIO3, GPIO4, GPIO5, GPIO6, RFCTRL1, RFCTRL2
Network status indication	Output indicating cellular network status: registered, data transmission, no service	--	GPIO1
External GNSS supply enable	Output to enable/disable the supply of an external u-blox GNSS receiver connected to the module by I2C	--	GPIO2
External GNSS data ready	Input to sense when an external u-blox GNSS receiver connected to the module is ready to send data over I2C	--	GPIO3
SIM card detection	Input for SIM card physical presence detection	--	GPIO6
Ring indicator	Output providing events indicator	--	RI
Module status indication	Output indicating module status: power-off or deep-sleep mode versus idle, active or connected mode	--	GPIO1, GPIO2, GPIO3, GPIO4, GPIO5, GPIO6
Last gasp	Input to trigger last gasp notification	--	GPIO3, GPIO4, GPIO5
Faster power-off	Input with internal pull-down to trigger a faster emergency shutdown (as AT+CFUN=10) by applying a rising edge	--	GPIO3, GPIO4

Function	Description	Default GPIO	Configurable GPIOs
Safe memory power-off	Input with internal pull-down to trigger the fastest memory-safe emergency shutdown (as AT+CFUN=11) by applying a rising edge	--	GPIO3, GPIO4
LwM2M pulse	Output to notify a settable LwM2M event with a configurable pulse	--	GPIO1, GPIO2, GPIO3, GPIO4, GPIO5, GPIO6
Antenna dynamic tuning	Output changing the status according to the RF band in use, to control in real time an external antenna tuning IC	--	RFCTRL1, RFCTRL2
Pin disabled	Tri-state with an internal active pull-down enabled	GPIO1, GPIO2, GPIO3, GPIO4, GPIO5, GPIO6, RI	GPIO1, GPIO2, GPIO3, GPIO4, GPIO5, GPIO6, RI

Table 4: GPIO custom functions configuration

2.7 Cellular antenna dynamic tuner interface

LEXI-R422 modules include two output pins (named **RFCTRL1** and **RFCTRL2**) that can optionally be used to control in real time an external antenna tuning IC, as the two pins change their output value dynamically according to the specific current LTE/2G band in use by the module. [Table 5](#) illustrates the default factory-programmed configuration that can be changed by dedicated AT command.

RFCTRL1	RFCTRL2	LTE frequency band in use	2G frequency band in use
0	0	--	--
0	1	B12, B13, B28, B85 (700..800 MHz)	--
1	0	B5, B8, B18, B19, B20, B26 (800..900 MHz)	GSM 850, E-GSM 900 (800..900 MHz)
1	1	B1, B2, B3, B4, B25, B66 (> 1000 MHz)	DCS 1800, PCS 1900 (> 1000 MHz)

Table 5: LEXI-R422 modules antenna dynamic tuning truth table (default factory-programmed configuration)

2.8 Reserved pin (RSVD)

LEXI-R422 modules include pins reserved for future use, marked as **RSVD**, which can all be left unconnected on the application board, except for the **RSVD** pin number **99** (also identified as **J5**), which is recommended to be externally accessible by connecting it to a dedicated Test-Point.

3 Pin definition

3.1 Pin assignment

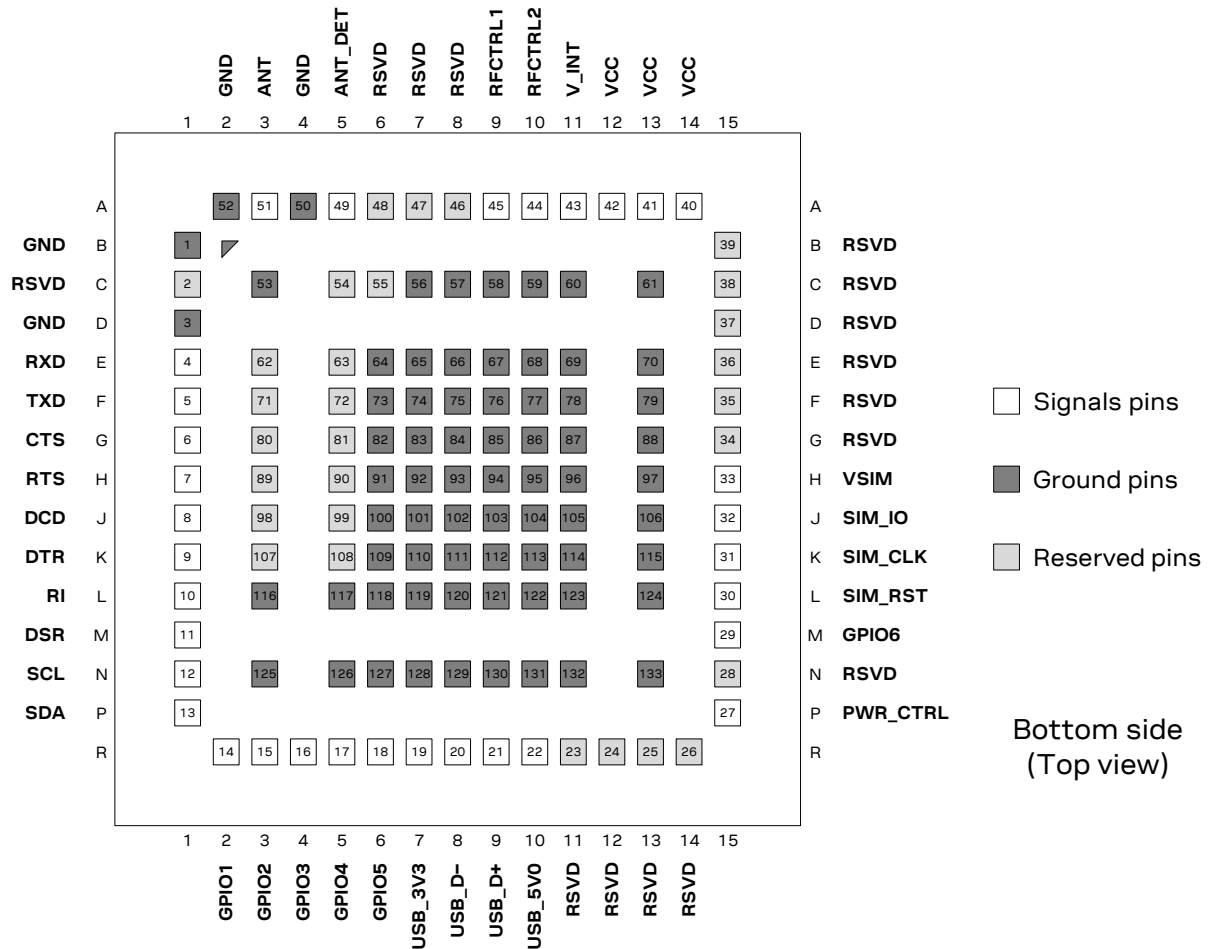

Figure 2: LEXI-R422 module pin assignment (top view)

ID	No	Name	Power domain	I/O	Description	Remarks
A2	52	GND	-	N/A	Ground	All the GND pins must be connected to ground.
A3	51	ANT	-	I/O	Cellular antenna	RF input/output for cellular Rx/Tx antenna. 50 Ω nominal impedance. See section 2.2.1 and 4.2.4 / 4.2.5 for details.
A4	50	GND	-	N/A	Ground	All the GND pins must be connected to ground.
A5	49	ANT_DET	ADC	I	Antenna detection	Antenna presence detection function. See section 2.2.2 for functional description. See section 4.2.6 for detailed electrical specs.
A6	48	RSVD	-	N/A	Reserved pin	Leave unconnected.
A7	47	RSVD	-	N/A	Reserved pin	Leave unconnected.
A8	46	RSVD	-	N/A	Reserved pin	Leave unconnected.
A9	45	RFCTRL1	GDI	O	RF GPIO for cellular antenna tuning	Digital output to optionally control an antenna tuning IC. Push-pull output type. See section 2.6 / 2.7 for functional description. See section 4.2.10 for detailed electrical specs.

ID	No	Name	Power domain	I/O	Description	Remarks
A10	44	RFCTRL2	GDI	O	RF GPIO for cellular antenna tuning	Digital output to optionally control an antenna tuning IC. Push-pull output type. See section 2.6 / 2.7 for functional description. See section 4.2.10 for detailed electrical specs.
A11	43	V_INT	-	O	Generic Digital Interfaces supply output	V_INT = 1.8 V (typical) supply generated by the module when is switched on, outside low power deep sleep mode. See section 2.1.2 for functional description. See section 4.2.2 for detailed electrical specs. Provide test point for diagnostic purposes.
A12	42	VCC	-	I	Module supply input	All VCC pins must be connected to external supply. Supply input for internal Power Management Unit See section 2.1.1 for functional description. See section 4.2.2 and 4.2.3 for detailed electrical specs.
A13	41	VCC	-	I	Module supply input	All VCC pins must be connected to external supply. Supply input for internal RF Power Amplifiers. See section 2.1.1 for functional description. See section 4.2.2 and 4.2.3 for detailed electrical specs.
A14	40	VCC	-	I	Module supply input	All VCC pins must be connected to external supply. Supply input for internal RF Power Amplifiers. See section 2.1.1 for functional description. See section 4.2.2 and 4.2.3 for detailed electrical specs.
B1	1	GND	-	N/A	Ground	All the GND pins must be connected to ground.
B15	39	RSVD	-	N/A	Reserved pin	Leave unconnected.
C1	2	RSVD	-	N/A	Reserved pin	Leave unconnected.
C3	53	GND	-	N/A	Ground	All the GND pins must be connected to ground.
C5	54	RSVD	-	N/A	Reserved pin	Leave unconnected.
C6	55	RSVD	-	N/A	Reserved pin	Leave unconnected.
C7	56	GND	-	N/A	Ground	All the GND pins must be connected to ground.
C8	57	GND	-	N/A	Ground	All the GND pins must be connected to ground.
C9	58	GND	-	N/A	Ground	All the GND pins must be connected to ground.
C10	59	GND	-	N/A	Ground	All the GND pins must be connected to ground.
C11	60	GND	-	N/A	Ground	All the GND pins must be connected to ground.
C13	61	GND	-	N/A	Ground	All the GND pins must be connected to ground.
C15	38	RSVD	-	N/A	Reserved pin	Leave unconnected.
D1	3	GND	-	N/A	Ground	All the GND pins must be connected to ground.
D15	37	RSVD	-	N/A	Reserved pin	Leave unconnected.
E1	4	RXD	GDI	O	UART data output	Circuit 104 in ITU-T V.24 (RxD data output, push-pull, idle high, active low). See section 2.5.1 for functional description. See section 4.2.10 for detailed electrical specs.
E3	62	RSVD	-	N/A	Reserved pin	Leave unconnected.
E5	63	RSVD	-	N/A	Reserved pin	Leave unconnected.
E6	64	GND	-	N/A	Ground	All the GND pins must be connected to ground.
E7	65	GND	-	N/A	Ground	All the GND pins must be connected to ground.
E8	66	GND	-	N/A	Ground	All the GND pins must be connected to ground.
E9	67	GND	-	N/A	Ground	All the GND pins must be connected to ground.
E10	68	GND	-	N/A	Ground	All the GND pins must be connected to ground.
E11	69	GND	-	N/A	Ground	All the GND pins must be connected to ground.
E13	70	GND	-	N/A	Ground	All the GND pins must be connected to ground.



ID	No	Name	Power domain	I/O	Description	Remarks
E15	36	RSVD	-	N/A	Reserved pin	Leave unconnected.
F1	5	TXD	GDI	I	UART data input	Circuit 103 in ITU-T V.24 (TxD data input, idle high, active low, with internal active pull-up enabled). See section 2.5.1 for functional description. See section 4.2.10 for detailed electrical specs.
F3	71	RSVD	-	N/A	Reserved pin	Leave unconnected.
F5	72	RSVD	-	N/A	Reserved pin	Leave unconnected.
F6	73	GND	-	N/A	Ground	All the GND pins must be connected to ground.
F7	74	GND	-	N/A	Ground	All the GND pins must be connected to ground.
F8	75	GND	-	N/A	Ground	All the GND pins must be connected to ground.
F9	76	GND	-	N/A	Ground	All the GND pins must be connected to ground.
F10	77	GND	-	N/A	Ground	All the GND pins must be connected to ground.
F11	78	GND	-	N/A	Ground	All the GND pins must be connected to ground.
F13	79	GND	-	N/A	Ground	All the GND pins must be connected to ground.
F15	35	RSVD	-	N/A	Reserved pin	Leave unconnected.
G1	6	CTS	GDI	O	UART clear to send	Circuit 106 in ITU-T V.24 (CTS hardware flow control output, push-pull, idle high, active low). See section 2.5.1 for functional description. See section 4.2.10 for detailed electrical specs.
G3	80	RSVD	-	N/A	Reserved pin	Leave unconnected.
G5	81	RSVD	-	N/A	Reserved pin	Leave unconnected.
G6	82	GND	-	N/A	Ground	All the GND pins must be connected to ground.
G7	83	GND	-	N/A	Ground	All the GND pins must be connected to ground.
G8	84	GND	-	N/A	Ground	All the GND pins must be connected to ground.
G9	85	GND	-	N/A	Ground	All the GND pins must be connected to ground.
G10	86	GND	-	N/A	Ground	All the GND pins must be connected to ground.
G11	87	GND	-	N/A	Ground	All the GND pins must be connected to ground.
G13	88	GND	-	N/A	Ground	All the GND pins must be connected to ground.
G15	34	RSVD	-	N/A	Reserved pin	Leave unconnected.
H1	7	RTS	GDI	I	UART request to send	Circuit 105 in ITU-T V.24 (RTS flow control input, idle high, active low, with internal active pull-up enabled). See section 2.5.1 for functional description. See section 4.2.10 for detailed electrical specs.
H3	89	RSVD	-	N/A	Reserved pin	Leave unconnected.
H5	90	RSVD	-	N/A	Reserved pin	Leave unconnected.
H6	91	GND	-	N/A	Ground	All the GND pins must be connected to ground.
H7	92	GND	-	N/A	Ground	All the GND pins must be connected to ground.
H8	93	GND	-	N/A	Ground	All the GND pins must be connected to ground.
H9	94	GND	-	N/A	Ground	All the GND pins must be connected to ground.
H10	95	GND	-	N/A	Ground	All the GND pins must be connected to ground.
H11	96	GND	-	N/A	Ground	All the GND pins must be connected to ground.
H13	97	GND	-	N/A	Ground	All the GND pins must be connected to ground.
H15	33	VSIM	-	O	SIM supply output	VSIM = 1.8 V (typical) supply generated by the module for external SIM / UICC, when it is switched on, after the internal boot sequence, outside low power deep sleep mode. See section 2.4.1 for functional description. See section 4.2.8 for detailed electrical specs.

ID	No	Name	Power domain	I/O	Description	Remarks
J1	8	DCD	GDI	O/ O	UART data carrier detect / AUX UART data output	Circuit 109 in ITU-T V.24 (DCD output, push-pull, idle high, active low), alternatively settable as Second Auxiliary UART RXD (data output, push-pull, idle high, active low). See section 2.5.1 for functional description. See section 4.2.10 for detailed electrical specs.
J3	98	RSVD	-	N/A	Reserved pin	Leave unconnected.
J5	99	RSVD	-	N/A	Reserved pin	Provide test point for diagnostic purposes.
J6	100	GND	-	N/A	Ground	All the GND pins must be connected to ground.
J7	101	GND	-	N/A	Ground	All the GND pins must be connected to ground.
J8	102	GND	-	N/A	Ground	All the GND pins must be connected to ground.
J9	103	GND	-	N/A	Ground	All the GND pins must be connected to ground.
J10	104	GND	-	N/A	Ground	All the GND pins must be connected to ground.
J11	105	GND	-	N/A	Ground	All the GND pins must be connected to ground.
J13	106	GND	-	N/A	Ground	All the GND pins must be connected to ground.
J15	32	SIM_IO	SIM	I/O	SIM data	Internal pull-up resistor to VSIM. See section 2.4.1 for functional description. See section 4.2.8 for detailed electrical specs.
K1	9	DTR	GDI	I/ I	UART data terminal ready / AUX UART data input	Circuit 108/2 in ITU-T V. 24 (DTR input, idle high, active low, with internal active pull-up enabled), alternatively settable as second auxiliary UART TXD (data input, idle high, active low, with internal active pull-up enabled). See section 2.5.1 for functional description. See section 4.2.10 for detailed electrical specs.
K3	107	RSVD	-	N/A	Reserved pin	Leave unconnected.
K5	108	RSVD	-	N/A	Reserved pin	Leave unconnected.
K6	109	GND	-	N/A	Ground	All the GND pins must be connected to ground.
K7	110	GND	-	N/A	Ground	All the GND pins must be connected to ground.
K8	111	GND	-	N/A	Ground	All the GND pins must be connected to ground.
K9	112	GND	-	N/A	Ground	All the GND pins must be connected to ground.
K10	113	GND	-	N/A	Ground	All the GND pins must be connected to ground.
K11	114	GND	-	N/A	Ground	All the GND pins must be connected to ground.
K13	115	GND	-	N/A	Ground	All the GND pins must be connected to ground.
K15	31	SIM_CLK	SIM	O	SIM clock	See section 2.4.1 for functional description. See section 4.2.8 for detailed electrical specs.
L1	10	RI	GDI	O/ O	UART ring indicator / AUX UART clear to send	Circuit 125 in ITU-T V.24 (RI output, push-pull, idle high, active low), alternatively configurable as second auxiliary UART CTS (HW flow control output, push-pull, idle high, active low). See section 2.5.1 for functional description. See section 4.2.10 for detailed electrical specs.
L3	116	GND	-	N/A	Ground	All the GND pins must be connected to ground.
L5	117	GND	-	N/A	Ground	All the GND pins must be connected to ground.
L6	118	GND	-	N/A	Ground	All the GND pins must be connected to ground.
L7	119	GND	-	N/A	Ground	All the GND pins must be connected to ground.
L8	120	GND	-	N/A	Ground	All the GND pins must be connected to ground.
L9	121	GND	-	N/A	Ground	All the GND pins must be connected to ground.
L10	122	GND	-	N/A	Ground	All the GND pins must be connected to ground.
L11	123	GND	-	N/A	Ground	All the GND pins must be connected to ground.
L13	124	GND	-	N/A	Ground	All the GND pins must be connected to ground.



ID	No	Name	Power domain	I/O	Description	Remarks
L15	30	SIM_RST	SIM	O	SIM reset	See section 2.4.1 for functional description. See section 4.2.8 for detailed electrical specs.
M1	11	DSR	GDI	O/I	UART data set ready / AUX UART request to send	Circuit 107 in ITU-T V.24 (DSR output, push-pull, idle high, active low), alternatively configurable as second auxiliary UART RTS (HW flow control input, idle high, active low, with internal active pull-up enabled). See section 2.5.1 for functional description. See section 4.2.10 for detailed electrical specs.
M15	29	GPIO6	GDI	I/O	Pin for SIM card detection	Configurable GPIO, alternatively configurable as input pin for SIM card detection. Push-pull output type. See sections 2.4.2 and 2.6 for functional description. See section 4.2.10 for detailed electrical specs.
N1	12	SCL	I2C	O	I2C bus clock line	Fixed open drain. Internal 2.2 kΩ pull-up to V_INT. Idle high, active low. See section 2.5.3 for functional description. See section 4.2.9 for detailed electrical specs.
N3	125	GND	-	N/A	Ground	All the GND pins must be connected to ground.
N5	126	GND	-	N/A	Ground	All the GND pins must be connected to ground.
N6	127	GND	-	N/A	Ground	All the GND pins must be connected to ground.
N7	128	GND	-	N/A	Ground	All the GND pins must be connected to ground.
N8	129	GND	-	N/A	Ground	All the GND pins must be connected to ground.
N9	130	GND	-	N/A	Ground	All the GND pins must be connected to ground.
N10	131	GND	-	N/A	Ground	All the GND pins must be connected to ground.
N11	132	GND	-	N/A	Ground	All the GND pins must be connected to ground.
N13	133	GND	-	N/A	Ground	All the GND pins must be connected to ground.
N15	28	RSVD	-	N/A	Reserved pin	Leave unconnected.
P1	13	SDA	I2C	I/O	I2C bus data line	Fixed open drain. Internal 2.2 kΩ pull-up to V_INT. Idle high, active low. See section 2.5.3 for functional description. See section 4.2.9 for detailed electrical specs.
P15	27	PWR_CTRL	POS	I	Power on/off control input	Internal active pull-up. Active low. See section 2.3.1 and 2.3.2 for functional description. See section 4.2.7 for detailed electrical specs. Provide test point for diagnostic purposes.
R2	14	GPIO1	GDI	I/O	GPIO	Configurable GPIO. Push-pull output type. See section 2.6 for functional description. See section 4.2.10 for detailed electrical specs.
R3	15	GPIO2	GDI	I/O	GPIO	Configurable GPIO. Push-pull output type. See section 2.6 for functional description. See section 4.2.10 for detailed electrical specs.
R4	16	GPIO3	GDI	I/O	GPIO	Configurable GPIO. Push-pull output type. See section 2.6 for functional description. See section 4.2.10 for detailed electrical specs.
R5	17	GPIO4	GDI	I/O	GPIO	Configurable GPIO. Push-pull output type. See section 2.6 for functional description. See section 4.2.10 for detailed electrical specs.
R6	18	GPIO5	GDI	I/O	GPIO	Configurable GPIO. Push-pull output type. See section 2.6 for functional description. See section 4.2.10 for detailed electrical specs.

ID	No	Name	Power domain	I/O	Description	Remarks
R7	19	USB_3V3	USB	I	USB supply input	Input for 3.3 V (typical) USB supply. USB interface supported for FW update and diagnostic only. See section 2.5.2 for functional description. See section 4.2.11 for detailed electrical specs. Provide test point for FW update and diagnostic purposes.
R8	20	USB_D-	USB	I/O	USB Data Line D-	90 Ω nominal differential impedance. Pull-up, pull-down and series resistors, as required by the USB 2.0 specifications [10], are part of the USB pin driver and shall not be provided externally. USB interface supported FW update and diagnostic only. See section 2.5.2 for functional description. See section 4.2.11 for detailed electrical specs. Provide test point for FW update and diagnostic purposes.
R9	21	USB_D+	USB	I/O	USB Data Line D+	90 Ω nominal differential impedance. Pull-up, pull-down and series resistors, as required by USB 2.0 specifications [10], are part of the USB pin driver and shall not be provided externally. USB interface supported for FW update and diagnostic only. See section 2.5.2 for functional description. See section 4.2.11 for detailed electrical specs. Provide test point for FW update and diagnostic purposes.
R10	22	USB_5V0	USB	I	USB detect input	Input for VBUS (5 V typical) USB supply sense. USB interface supported for FW update and diagnostic only. See section 2.5.2 for functional description. See section 4.2.11 for detailed electrical specs. Provide test point for FW update and diagnostic purposes.
R11	23	RSVD	-	N/A	Reserved pin	Leave unconnected.
R12	24	RSVD	-	N/A	Reserved pin	Leave unconnected.
R13	25	RSVD	-	N/A	Reserved pin	Leave unconnected.
R14	26	RSVD	-	N/A	Reserved pin	Leave unconnected.

Table 6: LEXI-R422 pin-out

-  For more information about the pin-out, see the LEXI-R422 system integration manual [2].
-  See appendix A for an explanation of the abbreviations and terms used.

4 Electrical specifications

-  Stressing the device above one or more of the ratings listed in the Absolute Maximum Rating section may cause permanent damage. These are stress ratings only. Operating the module at these or at any conditions other than those specified in the Operating Conditions sections (section 4.2) of the specification should be avoided. Exposure to Absolute Maximum Rating conditions for extended periods may affect device reliability.
-  Electrical characteristics are defined according to the verification on a representative number of samples or according to the simulation.
-  Where application information is given, it is advisory only and does not form part of the specification.

4.1 Absolute maximum rating

-  Limiting values given below are in accordance with Absolute Maximum Rating System (IEC 134).

Symbol	Description	Condition	Min.	Max.	Unit
VCC	Module supply voltage	Input DC voltage at VCC pins	-0.3	6.0	V
USB_5V0	USB detection pin	Input DC voltage at USB_5V0 pin	-0.3	5.5	V
USB	USB D+/D- pins	Input DC voltage at USB interface pins	-0.3	3.6	V
GDI	Generic digital interfaces	Input DC voltage at generic digital interfaces pins	-0.3	2.0	V
I2C	I2C interface	Input DC voltage at I2C interface pins	-0.3	2.0	V
SIM	SIM interface	Input DC voltage at SIM interface pins	-0.3	2.0	V
POS	Power-on input	Input DC voltage at PWR_CTRL pin	-0.3	1.8	V
ADC	Antenna detection input	Input DC voltage at ANT_DET pin	-0.3	1.8	V
P_RF	RF power	Input RF power at ANT pin		3	dBm
Rho_ANT	Antenna ruggedness	Output RF load mismatch ruggedness at ANT pin		10:1	VSWR
Tstg	Storage temperature		-40	+85	°C

Table 7: Absolute maximum ratings

-  The product is not protected against overvoltage or reversed voltages. If necessary, voltage spikes exceeding the voltage specifications given in the table above, must be limited to values within the specified boundaries by using appropriate protection devices.

4.1.1 Maximum ESD

Parameter	Min	Max	Unit	Remarks
ESD sensitivity for all pins		1000	V	Human Body Model according to JS-001-2017
		500	V	Charged Device Model according to JS-002-2018

Table 8: Maximum ESD ratings

-  u-blox cellular modules are electrostatic sensitive devices and require special precautions when handling. See section 7.3 for ESD handling instructions.

4.2 Operating conditions

 Unless otherwise indicated, all operating condition specifications are at an ambient temperature of +25 °C.

 Operation beyond the operating conditions is not recommended and extended exposure beyond them may affect device reliability.

4.2.1 Operating temperature range

Parameter	Min.	Typ.	Max.	Unit	Remarks
Normal operating temperature	-20	+25	+65	°C	Operating within 3GPP / ETSI specifications
Extended operating temperature	-40		+85	°C	Operating with possible slight deviation in RF performance outside normal operating range

Table 9: Environmental conditions

4.2.2 Supply/power pins

Symbol	Parameter	Min.	Typical	Max.	Unit
VCC	Module supply normal operating input voltage ²	3.2	3.8	4.5	V
	Module supply extended operating input voltage ³	3.0		4.5	V

Table 10: Input characteristics of the Supply/Power pins

Symbol	Parameter	Min.	Typical	Max.	Unit
VSIM	SIM supply output voltage with 1.8 V external SIM		1.8		V
V_INT	Generic Digital Interfaces supply output voltage		1.8		V
	Generic Digital Interfaces supply output current capability			70	mA

Table 11: Output characteristics of the Supply/Power pins

² Operating within 3GPP / ETSI specifications.

³ Operating with possible slight deviation in RF performance outside normal operating range. The input voltage has to be above the extended operating range minimum limit to switch-on the module and to avoid possible switch-off of the module.

⁴ Indicative current consumption values with VCC = 3.8 V

4.2.3 Current consumption

Mode	Condition	Tx power	Min	Typ	Max	Unit
Power Off Mode (module switched off)	Averaged current	--		3		µA
PSM Deep Sleep Mode	Averaged current	--		3		µA
Low Power Mode (+UPSV: 4)	Floor current (deep sleep in between eDRX cycles)	--		3		µA
	Floor current (no deep sleep in between eDRX cycles)	--		0.4		mA
	Averaged current (deep sleep in between eDRX cycle of 655.36 s)	--		0.1		mA
	Averaged current (no deep sleep in between eDRX cycle of 655.36 s)	--		0.5		mA
	Averaged current (no deep sleep in between eDRX cycle of 20.48 s)	--		0.6		mA
	Averaged current (2G DRX cycle of 1.2 s)	--		1.2		mA
Active Mode (Power Saving / Low Power Mode disabled, registered with network)	Averaged current	--		9		mA
LTE NB-IoT Connected Mode (Data Tx / Rx)	Averaged current during Tx / Rx	Minimum		65		mA
		Maximum		230		mA
	Peak current during Tx	Maximum			0.8	A
LTE Cat M1 Connected Mode (Data Tx / Rx)	Averaged current during Tx / Rx	Minimum		105		mA
		Maximum		350		mA
	Peak current value during Tx	Maximum			0.8	A
2G Connected Mode (Data Tx / Rx)	Averaged current value during GMSK 1-Tx/1-Rx call 850/900 MHz bands	Maximum		250		mA
	Peak current value during GMSK 1-slot Tx, 850/900 MHz bands	Maximum		1.9	2.5	A

Table 12: VCC current consumption of the LEXI-R422 module⁴

4.2.4 LTE RF characteristics

The LTE Cat M1 / NB2 bands supported by LEXI-R422 modules are defined in [Table 2](#), while [Table 13](#) describes the frequency ranges for each LTE band as per 3GPP TS 36.521-1 [7].

Parameter		Min.	Max.	Unit	Remarks
Frequency range FDD band 85 (700 MHz)	Uplink	698	716	MHz	Module transmits
	Downlink	728	746	MHz	Module receives
Frequency range FDD band 12 (700 MHz)	Uplink	699	716	MHz	Module transmits
	Downlink	729	746	MHz	Module receives
Frequency range FDD band 28 (700 MHz)	Uplink	703	748	MHz	Module transmits
	Downlink	758	803	MHz	Module receives
Frequency range FDD band 13 (750 MHz)	Uplink	777	787	MHz	Module transmits
	Downlink	746	756	MHz	Module receives
Frequency range FDD band 20 (800 MHz)	Uplink	832	862	MHz	Module transmits
	Downlink	791	821	MHz	Module receives

⁴ Indicative current consumption values with VCC = 3.8 V

Parameter		Min.	Max.	Unit	Remarks
Frequency range FDD band 26 (850 MHz)	Uplink	814	849	MHz	Module transmits
	Downlink	859	894	MHz	Module receives
Frequency range FDD band 18 (850 MHz)	Uplink	815	830	MHz	Module transmits
	Downlink	860	875	MHz	Module receives
Frequency range FDD band 5 (850 MHz)	Uplink	824	849	MHz	Module transmits
	Downlink	869	894	MHz	Module receives
Frequency range FDD band 19 (850 MHz)	Uplink	830	845	MHz	Module transmits
	Downlink	875	890	MHz	Module receives
Frequency range FDD band 8 (900 MHz)	Uplink	880	915	MHz	Module transmits
	Downlink	925	960	MHz	Module receives
Frequency range FDD band 4 (1700 MHz)	Uplink	1710	1755	MHz	Module transmits
	Downlink	2110	2155	MHz	Module receives
Frequency range FDD band 66 (1700 MHz)	Uplink	1710	1780	MHz	Module transmits
	Downlink	2110	2200	MHz	Module receives
Frequency range FDD band 3 (1800 MHz)	Uplink	1710	1785	MHz	Module transmits
	Downlink	1805	1880	MHz	Module receives
Frequency range FDD band 2 (1900 MHz)	Uplink	1850	1910	MHz	Module transmits
	Downlink	1930	1990	MHz	Module receives
Frequency range FDD band 25 (1900 MHz)	Uplink	1850	1915	MHz	Module transmits
	Downlink	1930	1995	MHz	Module receives
Frequency range FDD band 1 (2100 MHz)	Uplink	1920	1980	MHz	Module transmits
	Downlink	2110	2170	MHz	Module receives

Table 13: LTE operating RF frequency bands

LEXI-R422 modules include a UE Power Class 3 LTE Cat M1 / NB2 transmitter (see [Table 2](#)) and an LTE receiver, with output power and characteristics according to 3GPP TS 36.521-1 [\[7\]](#).

The LEXI-R422 module's LTE receiver characteristics are compliant to 3GPP TS 36.521-1 [\[7\]](#), with LTE conducted receiver sensitivity performance described in [Table 14](#) and [Table 15](#).

Parameter	Min.	Typical	Max.	Unit	Remarks
Receiver input sensitivity Band 12 / 28 / 85 (700 MHz)		-108.5		dBm	Without repetitions
Receiver input sensitivity Band 13 (750 MHz)		-108.5		dBm	Without repetitions
Receiver input sensitivity Band 20 (800 MHz)		-108.0		dBm	Without repetitions
Receiver input sensitivity Band 5 / 18 / 19 / 26 (850 MHz)		-108.0		dBm	Without repetitions
Receiver input sensitivity Band 8 (900 MHz)		-107.5		dBm	Without repetitions
Receiver input sensitivity Band 3 (1800 MHz)		-108.0		dBm	Without repetitions
Receiver input sensitivity Band 2 / 25 (1900 MHz)		-108.0		dBm	Without repetitions
Receiver input sensitivity Band 1 / 4 / 66 (2100 MHz)		-108.0		dBm	Without repetitions

Condition: 50 Ω source, throughput > 95%, QPSK modulation, other settings as per clause 7.3EA of 3GPP TS 36.521-1 [\[7\]](#)

Table 14: LTE Cat M1 receiver sensitivity performance

Parameter	Min.	Typical	Max.	Unit	Remarks
Receiver input sensitivity Band 12 / 28 / 85 (700 MHz)		-116.5		dBm	Without repetitions
Receiver input sensitivity Band 13 (750 MHz)		-116.5		dBm	Without repetitions
Receiver input sensitivity Band 20 (800 MHz)		-116.0		dBm	Without repetitions
Receiver input sensitivity Band 5 / 18 / 19 / 26 (850 MHz)		-116.0		dBm	Without repetitions
Receiver input sensitivity Band 8 (900 MHz)		-116.0		dBm	Without repetitions
Receiver input sensitivity Band 3 (1800 MHz)		-116.0		dBm	Without repetitions
Receiver input sensitivity Band 2 / 25 (1900 MHz)		-116.0		dBm	Without repetitions
Receiver input sensitivity Band 1 / 4 / 66 (2100 MHz)		-116.0		dBm	Without repetitions

Condition: 50 Ω source, throughput > 95%, QPSK modulation, other settings as per clause 7.3F of 3GPP TS 36.521-1 [7]

Table 15: LTE Cat NB2 receiver sensitivity performance

4.2.5 2G RF characteristics

The 2G bands supported by LEXI-R422 modules are defined in the [Table 2](#), while the following [Table 16](#) describes the Transmitting and Receiving frequencies according to 3GPP TS 51.010-1 [8].

Parameter		Min	Max	Unit	Remarks
Frequency range GSM 850	Uplink	824	849	MHz	Module transmits
	Downlink	869	894	MHz	Module receives
Frequency range E-GSM 900	Uplink	880	915	MHz	Module transmits
	Downlink	925	960	MHz	Module receives
Frequency range DCS 1800	Uplink	1710	1785	MHz	Module transmits
	Downlink	1805	1880	MHz	Module receives
Frequency range PCS 1900	Uplink	1850	1910	MHz	Module transmits
	Downlink	1930	1990	MHz	Module receives

Table 16: 2G operating RF frequency bands

LEXI-R422 modules include a GMSK Power Class 4 transmitter for the GSM 850 and E-GSM 900 bands, a GMSK Power Class 1 transmitter for the DCS 1800 and PCS 1900 bands, a 8-PSK Power Class E2 transmitter for all the 2G bands (see [Table 2](#)), with output power and characteristics according to 3GPP TS 51.010-1 [8].

LEXI-R422 modules 2G receiver characteristics are compliant to 3GPP TS 51.010-1 [8], with conducted receiver sensitivity performance described in [Table 17](#).

Parameter	Min	Typical	Max	Unit	Remarks
GSM 850 receiver input sensitivity		-109		dBm	Downlink RF level @ BER Class II < 2.4 %
E-GSM 900 receiver input sensitivity		-109		dBm	Downlink RF level @ BER Class II < 2.4 %
DCS 1800 receiver input sensitivity		-109		dBm	Downlink RF level @ BER Class II < 2.4 %
PCS 1900 receiver input sensitivity		-109		dBm	Downlink RF level @ BER Class II < 2.4 %

Condition: 50 Ω source

Table 17: 2G receiver sensitivity performance

4.2.6 ANT_DET pin

Pin Name	Parameter	Min.	Typ.	Max.	Unit	Remarks
ANT_DET	Output DC current pulse value		35		μA	
	Output DC current pulse time length		1160		μs	

Table 18: ANT_DET pin characteristics

4.2.7 PWR_CTRL pin

Parameter	Min.	Typical	Max.	Unit	Remarks
Internal supply for PWR_CTRL Input Signal		1.5		V	The PWR_CTRL input is pulled up to an internal voltage rail.
Low-level input	-0.30		0.35	V	
PWR_CTRL low time	0.01		12.0	s	Low time to trigger module switch on from power off mode
	0.01		12.0	s	Low time to trigger module wake-up from PSM deep sleep
	1.10		14.0	s	Low time to trigger module graceful switch off
	16.0			s	Low time to trigger module abrupt emergency reset (reboot)

Table 19: PWR_CTRL pin characteristics

4.2.8 SIM pins

The SIM pins are a dedicated interface to the external SIM card/chip. The electrical characteristics fulfill the regulatory specification requirements. The values in [Table 20](#) are for information only.

Parameter	Min.	Typical	Max.	Unit	Remarks
Internal supply domain for SIM interface		1.8		V	VSIM, with external 1.8 V SIM type
Low-level input	-0.3		0.4	V	
High-level input	1.1		2.0	V	
Low-level output		0.0		V	
High-level output		1.8		V	
Internal pull-up resistor on SIM_IO		4.7		kΩ	Internal pull-up to VSIM supply
Clock frequency on SIM_CLK		4.8		MHz	

Table 20: SIM pins characteristics

4.2.9 I2C pins

I2C lines (**SCL** and **SDA**) are compliant to the I2C-bus standard mode specification. See the I2C-bus specification [11] for detailed electrical characteristics.

Parameter	Min	Typical	Max	Unit	Remarks
Internal supply for I2C domain		1.8		V	Digital I/O Interfaces supply (V_INT)
Low-level input	-0.3		0.5	V	
High-level input	1.3		2.1	V	
Low-level output		0.0		V	
Internal pull-up resistance		2.2		kΩ	

Table 21: I2C pins characteristics

4.2.10 Generic Digital Interfaces pins

Parameter	Min	Typical	Max	Unit	Remarks
Internal supply for GDI domain		1.8		V	Digital I/O Interfaces supply (V_INT)
Low-level input	-0.3		0.6	V	
High-level input	1.2		2.0	V	
Low-level output		0.0	0.4	V	Max value at IOL = +2.0 mA
High-level output	1.4	1.8		V	Min value at IOH = -2.0 mA
Internal pull-up / pull-down resistance	55		390	k Ω	

Table 22: GDI pins characteristics

4.2.11 USB pins

USB data lines (**USB_D+** / **USB_D-**) are compliant with the USB 2.0 high-speed specification. See the Universal Serial Bus specification revision 2.0 [10] for detailed electrical characteristics. The values in [Table 23](#) related to USB 2.0 high-speed physical layer specifications are for information only.

Parameter	Min.	Typical	Max.	Unit	Remarks
Input voltage on pin USB_5V0	4.40	5.00	5.25	V	Sense input to enable the USB interface
Input voltage on pin USB_3V3		3.30		V	Supply input for the USB interface
High-speed squelch detection threshold (input differential signal amplitude)	100		150	mV	
High speed disconnect detection threshold (input differential signal amplitude)	525		625	mV	
High-speed data signaling input common mode voltage range	-50		500	mV	
High-speed idle output level	-10		10	mV	
High-speed data signaling output high level	360		440	mV	
High-speed data signaling output low level	-10		10	mV	
Chirp J level (output differential voltage)	700		1100	mV	
Chirp K level (output differential voltage)	-900		-500	mV	

Table 23: USB pins characteristics

5 Mechanical specifications

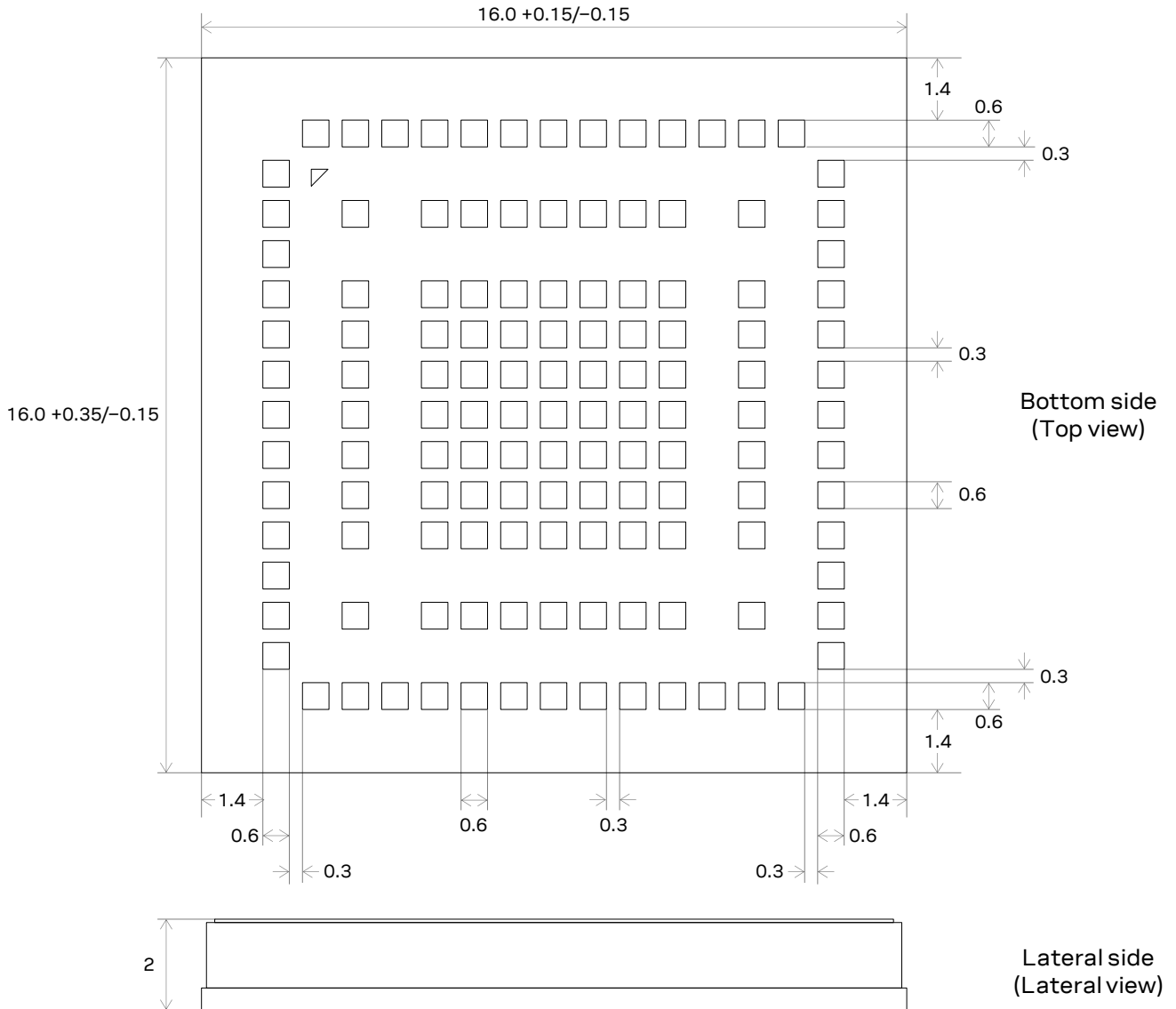



Figure 3: LEXI-R422 dimensions, typical values [mm]

-  Actual geometries of the pads may depend on related implementation of the solder resist mask openings and the underlying copper layer.
-  For information regarding Footprint and Stencil design recommended for the application board integrating the cellular module, see the LEXI-R422 system integration manual [2].

6 Qualification and approvals

6.1 Reliability tests

Reliability tests for LEXI-R422 modules are executed according to u-blox qualification policy, based on AEC-Q104 standard.

6.2 Approvals

LEXI-R422 modules comply with the Directive 2011/65/EU of the European Parliament and the Council on the Restriction of Use of certain Hazardous Substances in Electrical and Electronic Equipment (EU RoHS 2) and its amendment Directive (EU) 2015/863 (EU RoHS 3).



LEXI-R422 modules are RoHS 3 compliant.

No natural rubbers, hygroscopic materials, or materials containing asbestos are employed.

[Table 24](#) summarizes the main approvals planned for LEXI-R422 modules.

Certification	LEXI-R422
PTCRB	LTE-M bands 1, 2, 3, 4, 5, 8, 12, 13, 18, 19, 20, 25, 26, 28, 66 NB-IoT bands 1, 2, 3, 4, 5, 8, 12, 13, 18, 19, 20, 28, 66, 85 2G bands 850, 900, 1800, 1900
GCF	LTE-M bands 1, 2, 3, 4, 5, 8, 12, 13, 18, 19, 20, 25, 26, 28, 66 NB-IoT bands 1, 2, 3, 4, 5, 8, 12, 13, 18, 19, 20, 28, 66, 85 2G bands 850, 900, 1800, 1900
CE Europe	LTE-M bands 1, 3, 8, 20, 28 NB-IoT bands 1, 3, 8, 20, 28 2G bands 900, 1800
UKCA Great Britain	LTE-M bands 1, 3, 8, 20, 28 NB-IoT bands 1, 3, 8, 20, 28 2G bands 900, 1800
FCC United States	LTE-M bands 2, 4, 5, 8, 12, 13, 25, 26, 66 NB-IoT bands 2, 4, 5, 8, 12, 13, 66, 85 2G bands 850, 1900
FCC ID	XPYUBX22VA03
ISED Canada	LTE-M bands 2, 4, 5, 12, 13, 25, 26, 66 NB-IoT bands 2, 4, 5, 12, 13, 66, 85 2G bands 850, 1900
ISED Certification Number	8595A-UBX22VA03
NCC Taiwan	LTE-M bands 3, 8, 28 NB-IoT bands 3, 8, 28
ANATEL Brazil	LTE-M bands 1, 2, 3, 5, 8, 28 NB-IoT bands 1, 2, 3, 5, 8, 28 2G bands 850, 900, 1800, 1900
Vodafone	LTE-M bands 3, 8, 20 NB-IoT bands 3, 8, 20 2G bands 900, 1800
Deutsche Telekom	LTE-M bands 3, 8, 20 NB-IoT bands 3, 8, 20 2G bands 900, 1800

Table 24: LEXI-R422 main certification approvals summary

-  For guidelines and notices about compliance with the various certification approvals requirements integrating LEXI-R422 modules in host devices, see the LEXI-R422 system integration manual [\[2\]](#).
-  For the complete list of achieved or planned approvals, and for specific details on all country, conformance and network operators' certifications available for the LEXI-R422 modules, including related certificates, please contact your nearest u-blox office or sales representative.

7 Product handling & soldering

7.1 Packaging

LEXI-R422 modules are delivered as hermetically sealed, reeled tapes to enable efficient production, production lot set-up and tear-down. For more information about packaging, see the u-blox package information user guide [3].

7.1.1 Reels

LEXI-R422 modules are deliverable in quantities of 500 pieces on a reel. The modules are delivered using reel type A4 described in the u-blox package information user guide [3].

Quantities of less than 500 pieces are also available. Contact u-blox for more information.

7.1.2 Tapes

LEXI-R422 modules are delivered on the tape illustrated in Figure 4.

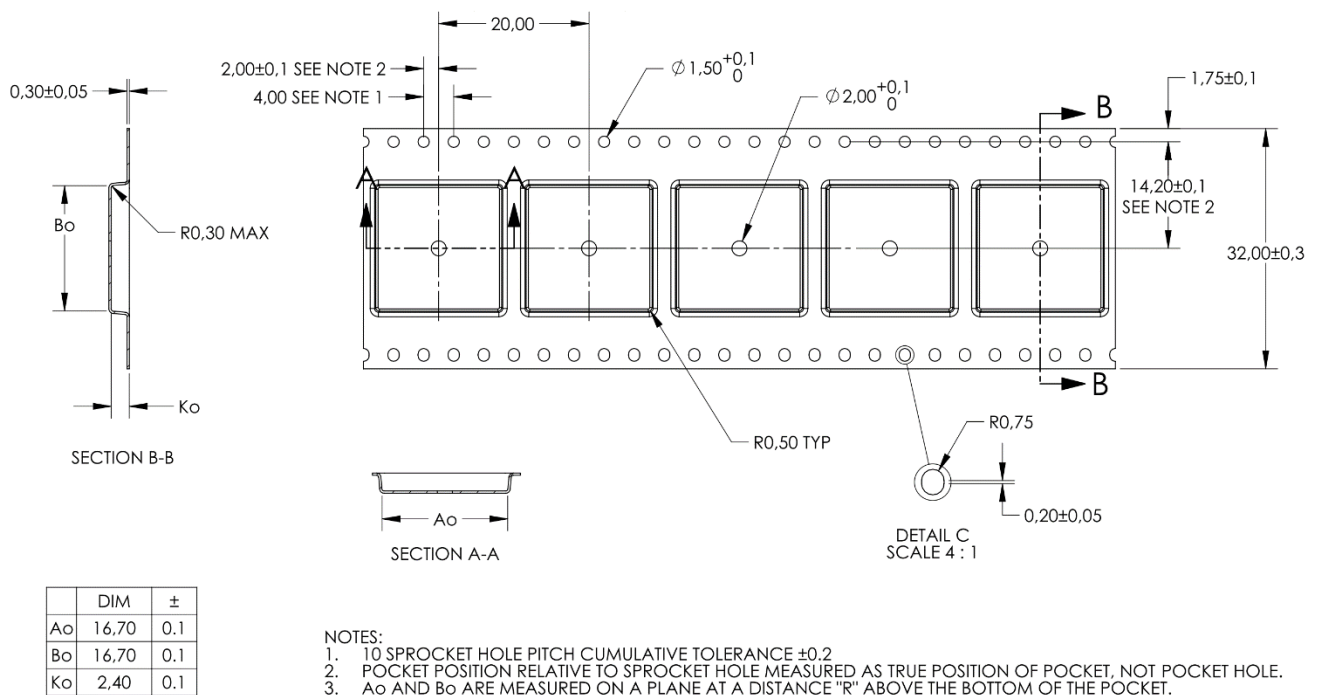

Figure 4: LEXI-R422 modules tape (all dimensions in millimeters)

7.2 Moisture sensitivity levels

LEXI-R422 modules are moisture sensitive devices (MSD) in accordance to the related IPC/JEDEC specifications.

The Moisture Sensitivity Level (MSL) relates to the packaging and handling precautions required. LEXI-R422 modules are rated at MSL level 4. For more information regarding moisture sensitivity levels, labeling, storage and drying, see the u-blox package information user guide [3].

For the MSL standard, see IPC/JEDEC J-STD-020 (can be downloaded from www.jedec.org).

7.3 ESD precautions

- ⚠ LEXI-R422 modules contain highly sensitive electronic circuitry and are Electrostatic Sensitive Devices (ESD). Handling LEXI-R422 modules without proper ESD protection may destroy or damage them permanently.
- ⚠ Ensure ESD precautions are implemented during handling of the module.



Electrostatic discharge (ESD) is the sudden and momentary electric current that flows between two objects at different electrical potentials caused by direct contact or induced by an electrostatic field. The term is usually used in the electronics and other industries to describe momentary unwanted currents that may cause damage to electronic equipment.

[Table 8](#) details the maximum ESD ratings of the LEXI-R422 modules.

Proper ESD handling and packaging procedures must be applied throughout the processing, handling and operation of any application that incorporates LEXI-R422 modules.

ESD precautions should be appropriately implemented on the application board where the module is mounted, as described in the LEXI-R422 system integration manual [\[2\]](#).

- ⚠ Failure to observe these precautions can result in severe damage to the device!

7.4 Reflow soldering

Reflow profiles are to be selected according to u-blox recommendations, as illustrated in details in the LEXI-R422 system integration manual [\[2\]](#).

- ⚠ Failure to observe these recommendations can result in severe damage to the device!

8 Labeling and ordering information

8.1 Product labeling

The labels of LEXI-R422 modules include important product information, as described in this section. [Figure 5](#) provides an illustrative example of LEXI-R422 modules' label, which includes for example: the u-blox logo (acting also as pin 1 indicator), production date, Pb-free marking, product type number, IMEI number, certification info, and production country of the module.



Figure 5: Illustrative example of LEXI-R422 modules' label

8.2 Explanation of codes

Three different product code formats are used. The **Product name** is used in documentation such as this data sheet and identifies all the u-blox products, independent of packaging and quality grade. The **Ordering code** includes options and quality, while the **Type number** includes the hardware and firmware versions. [Table 25](#) details these 3 different formats:

Format	Structure
Product name	PPPP-TGVV
Ordering code	PPPP-TGVV-MMQ
Type number	PPPP-TGVV-MMQ-XX

Table 25: Product code formats

[Table 26](#) explains the parts of the product code.

Code	Meaning	Example
PPPP	Form factor	LEXI
TG	Platform (Technology and Generation) <ul style="list-style-type: none"> Dominant technology: G = GSM, U = UMTS, C = CDMA, N = NB-IoT (LTE Cat NB1/NB2), R = LTE low data rate (Cat M1, Cat 1, Cat 1bis), L = LTE high data rate (Cat 3 and above) Generation: 1...9 	R4
VV	Variant function set based on the same platform: 00...99	22
MM	Major product version: 00...99	01
Q	Product grade: C = standard, B = professional, A = automotive	B
XX	Minor product version: 00...99	Default value: 00

Table 26: Part identification code

8.3 Ordering information

Ordering No.	Product
LEXI-R422-01B	LTE Cat M1 / NB2 and 2G module. 16.0 x 16.0 mm

Table 27: Product ordering codes

Appendix

A Glossary

Abbreviation	Definition
3GPP	3 rd Generation Partnership Project
8-PSK	8 Phase-Shift Keying modulation
ACMA	Australian Communications and Media Authority
ADC	Analog to Digital Converter
ANATEL	Agência Nacional de Telecomunicações - National Telecommunications Agency (Brazil)
Cat	Category
CE	European Conformity
CLK	Clock
CMOS	Complementary Metal-Oxide-Semiconductor
CoAP	Constrained Application Protocol
CTS	Clear To Send
DC	Direct Current
DCD	Data Carrier Detect
DL	Down Link (Reception)
DRX	Discontinuous Reception
DSR	Data Set Ready
DTE	Data Terminal Equipment
DTLS	Datagram Transport Layer Security
DTR	Data Terminal Ready
eDRX	Extended Discontinuous Reception
ESD	Electrostatic Discharge
E-UTRA	Evolved Universal Terrestrial Radio Access
FCC	Federal Communications Commission United States
FDD	Frequency Division Duplex
FOAT	Firmware (update) Over AT commands
FOTA	Firmware (update) Over-The-Air
FTP	File Transfer Protocol
GCF	Global Certification Forum
GDI	Generic Digital Interface
GND	Ground
GNSS	Global Navigation Satellite System
GMSK	Gaussian Minimum-Shift Keying modulation
GPIO	General Purpose Input/Output
HDLC	High-level Data Link Control
HTTP	HyperText Transfer Protocol
ID	Identifier
I2C	Inter-Integrated Circuit
I2S	Inter-IC Sound
I/O	Input/Output
IMEI	International Mobile Equipment Identity
ISED	Innovation, Science and Economic Development Canada

Abbreviation	Definition
LGA	Land Grid Array
LPWA	Low Power Wide Area
LTE	Long-Term Evolution
LTE-M	Long-Term Evolution – enhanced Machine Type Communication (LTE Category M1)
LwM2M	Lightweight Machine-to-Machine protocol
M2M	Machine to Machine
MQTT	Message Queuing Telemetry Transport
MQTT-SN	Message Queuing Telemetry Transport for Sensor Networks
N/A	Not Applicable
NB-IoT	Narrowband Internet of Things (LTE Category NB1 / LTE Category NB2)
NCC	National Communications Commission Taiwan
No	Number
PCN	Product Change Notification / Sample Delivery Note / Information Note
PMU	Power Management Unit
POS	Power On Signal
PSM	Power Saving Mode
PTCRB	PCS Type Certification Review Board
QPSK	Quadrature Phase Shift Keying modulation
RAT	Radio Access Technology
RCM	Regulatory Compliance Mark (Australia)
RED	Radio Equipment Directive (European Union)
RF	Radio Frequency
RI	Ring Indicator
RIL	Radio Interface Layer
RTC	Real Time Clock
RTS	Request To Send
Rx	Reception
SCL	Serial Clock
SDA	Serial Data
SIM	Subscriber Identity Module
SSL	Secure Socket Layer
TCP	Transmission Control Protocol
TLS	Transport Layer Security
TS	Technical Specification
Tx	Transmission
UART	Universal Asynchronous Receiver/Transmitter
UDP	User Datagram Protocol
UE	User Equipment
uFOTA	u-blox Firmware (update) Over-The-Air
UKCA	United Kingdom Conformity Assessed
UL	Uplink (Transmission)
USB	Universal Serial Bus
VSWR	Voltage Standing Wave Ratio

Related documentation

- [1] u-blox LEXI-R422 / SARA-R4 series AT commands manual, [UBX-17003787](#)
- [2] u-blox LEXI-R422 system integration manual, [UBX-23007449](#)
- [3] u-blox package information user guide, [UBX-14001652](#)
- [4] 3GPP TS 27.007 – AT command set for User Equipment (UE)
- [5] 3GPP TS 27.005 – Use of Data Terminal Equipment – Data Circuit terminating Equipment (DTE – DCE) interface for Short Message Service (SMS) and Cell Broadcast Service (CBS)
- [6] 3GPP TS 27.010 – Terminal Equipment to User Equipment (TE-UE) multiplexer protocol
- [7] 3GPP TS 36.521-1 – Evolved Universal Terrestrial Radio Access; User Equipment conformance specification; Radio transmission and reception; Part 1: Conformance Testing
- [8] 3GPP TS 51.010-1 - Mobile Station conformance specification; part 1: conformance specification
- [9] ITU-T Recommendation V24 – List of definitions for interchange circuits between Data Terminal Equipment (DTE) and Data Connection Equipment (DCE)
- [10] Universal Serial Bus Revision 2.0 specification, <https://www.usb.org/>
- [11] I2C-bus specification and user manual – UM10204 – NXP semiconductors, <https://www.nxp.com/docs/en/user-guide/UM10204.pdf>
- [12] RFC 7252 - Constrained Application Protocol (CoAP)

 For regular updates to u-blox documentation and to receive product change notifications, register on our homepage (www.u-blox.com).

Revision history

Revision	Date	Name	Comments
R01	23-May-2023	sses	Initial release
R02	30-Jun-2023	sses	Updated LEXI-R422-01B product status to prototype. Minor corrections and clarifications.
R03	06-Oct-2023	sses	Updated LEXI-R422-01B product status to engineering sample. Added memory-safe emergency power-off function. Minor other corrections and clarifications.

Contact

u-blox AG

Address: Zürcherstrasse 68
8800 Thalwil
Switzerland

For further support and contact information, visit us at www.u-blox.com/support.