

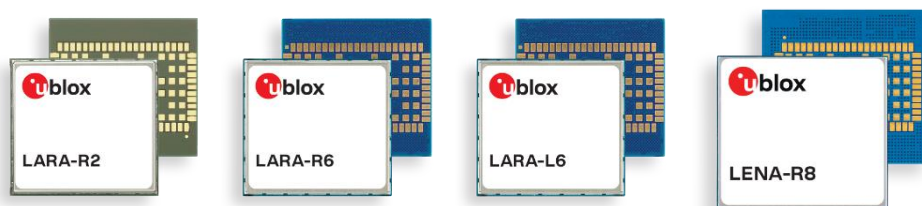

LARA / LENA HW migration

Guidelines for LARA / LENA modules HW migration

Application note



Abstract

This document provides hardware guidelines to migrate from the u-blox LARA-R2 region-specific LTE Cat 1 / 3G / 2G modules to u-blox LARA-R6 global and multi-region LTE Cat 1 / 3G / 2G modules, u-blox LARA-L6 global and multi-region LTE Cat 4 / 3G / 2G modules, and the u-blox LENA-R8 global LTE Cat 1bis / 2G modules, which are designed in the u-blox LARA and LENA compatible form factors

Document information

Title	LARA / LENA HW migration	
Subtitle	Guidelines for LARA / LENA modules HW migration	
Document type	Application note	
Document number	UBX-21010015	
Revision and date	R05	10-Oct-2023
Disclosure restriction	C1-Public	

This document applies to the following products:

Product name	Ordering code
LARA-R202	LARA-R202-02B
	LARA-R202-82B
	LARA-R202-03B
LARA-R203	LARA-R203-02B
	LARA-R203-03B
LARA-R204	LARA-R204-02B
LARA-R211	LARA-R211-02B
	LARA-R211-03B
LARA-R220	LARA-R220-62B
LARA-R280	LARA-R280-02B
LARA-R281	LARA-R281-02B
LARA-R6001	LARA-R6001-00B
	LARA-R6001-01B
LARA-R6001D	LARA-R6001D-00B
	LARA-R6001D-01B
LARA-R6401	LARA-R6401-00B
	LARA-R6401-01B
LARA-R6401D	LARA-R6401D-00B
	LARA-R6401D-01B
LARA-R6801	LARA-R6801-00B
	LARA-R6801-01B
LARA-R6801D	LARA-R6801D-01B
LARA-L6004	LARA-L6004-00B
	LARA-L6004-01B
LARA-L6004D	LARA-L6004D-00B
	LARA-L6004D-01B
LARA-L6804D	LARA-L6804D-01B
LENA-R8001	LENA-R8001-00C
LENA-R8001M10	LENA-R8001M10-00C

u-blox or third parties may hold intellectual property rights in the products, names, logos and designs included in this document. Copying, reproduction, modification or disclosure to third parties of this document or any part thereof is only permitted with the express written permission of u-blox.

The information contained herein is provided "as is" and u-blox assumes no liability for its use. No warranty, either express or implied, is given, including but not limited to, with respect to the accuracy, correctness, reliability and fitness for a particular purpose of the information. This document may be revised by u-blox at any time without notice. For the most recent documents, visit www.u-blox.com.

Copyright © u-blox AG.

Contents

Document information	2
Contents	3
1 LARA and LENA modules description	4
1.1 Overview.....	4
1.2 Product features	5
2 Migration between LARA and LENA modules	9
2.1 Overview.....	9
2.2 Pin-out comparison between LARA and LENA modules	11
2.3 Interfaces comparison between LARA and LENA modules.....	18
2.3.1 VCC module supply input.....	18
2.3.2 V_INT 1.8 V supply output	18
2.3.3 V_BCKP RTC supply input/output.....	19
2.3.4 Cellular RF interfaces.....	19
2.3.5 System control interfaces	20
2.3.6 SIM interface	21
2.3.7 UART interfaces.....	21
2.3.8 USB interface.....	22
2.3.9 I2C interface.....	23
2.3.10 Digital audio interface.....	23
2.3.11 Clock output.....	23
2.3.12 GPIOs.....	24
2.3.13 Antenna dynamic tuning.....	24
2.3.14 Reserved pins	24
2.3.15 GNSS interfaces.....	24
2.3.16 Other considerations and test points	25
2.4 Schematic for LARA and LENA modules integration.....	26
Appendix	27
A Glossary	27
Related documentation	29
Revision history	29
Contact	29

1 LARA and LENA modules description

1.1 Overview

The u-blox LARA-R2 series modules support the LTE Cat 1 FDD multi-band radio access technology, with 3G UMTS/HSPA FDD multi-band fallback or 2G GSM/GPRS/EGPRS dual-band fallback available with some product versions. These series modules provide the ideal solution for applications requiring limited data rate, region-specific coverage, and selected product versions also has voice capability. Detailed description of LARA-R2 series modules is available in the LARA-R2 series data sheet [1], while design guidelines are available in the LARA-R2 series system integration manual [2] and the supported AT commands are described in the u-blox AT commands manual [9].

The u-blox LARA-R6 series modules support LTE Cat 1 FDD/TDD multi-band radio access technology, with 3G UMTS/HSPA FDD multi-band and 2G GSM/GPRS/EGPRS quad-band fallback available with some product versions. These series modules provide the ideal solution for applications requiring limited data rate, global coverage, and selected product versions also has voice capability. Detailed description of LARA-R6 series modules is available in the LARA-R6 series data sheet [4]. The design guidelines are available in LARA-R6/L6 series system integration manual [6], and the supported AT commands are described in the LARA-R6/L6 series AT commands manual [10].

The u-blox LARA-L6 series modules support LTE Cat 4 FDD/TDD multi-band radio access technology, with 3G UMTS/HSPA FDD multi-band and 2G GSM/GPRS/EGPRS quad-band fallback. These series modules provide the ideal solution for applications requiring high data rate and global or multi-region coverage. Additionally, LARA-L6 modules are pin-to-pin compatible with LARA-R6 modules, with the same electrical characteristics in all available interfaces, except the support of the LTE Cat 4, instead of the LTE Cat 1 radio access technology. The designed pin-to-pin compatibility allows seamless migration from any LARA-R6 and/or LARA-L6 module product version, as illustrated in this document. Detailed description of LARA-L6 series modules is available in the LARA-L6 series data sheet [5]. The design guidelines are available in the LARA-R6/L6 series system integration manual [6] and the supported AT commands are described in the LARA-R6/L6 series AT commands manual [10].

All the LARA-R2, LARA-R6, LARA-L6 modules are available in the same small LARA LGA form-factor (26 x 24 mm, 100-pin), allowing easy migration from any LARA module product version to the other, and easy integration in small designs.

The u-blox LENA-R8 modules support LTE Cat 1bis FDD/TDD multi-band radio access technology, with 2G GSM/GPRS quad-band fallback. These series modules provide the ideal cost-saving solution for applications requiring limited data rate and global coverage. The specific LENA-R8001M10 module also has the GNSS positioning feature available, with the u-blox M10 GNSS receiver integrated in. Detailed description of LENA-R8 series modules is available in the LENA-R8 series data sheet [7]. The design guidelines are available in the LENA-R8 series system integration manual [8] and the supported AT commands are described in the LENA-R8 series AT commands manual [11].

LENA-R8 series modules are available in the compact LENA LGA form-factor (30 x 27 mm, 100-pin), having the same footprint design of the LARA LGA form-factor modules, allowing easy migration from any LARA or LENA module product version to the other, and easy integration in compact designs.

All the LARA and LENA series modules are also form-factor compatible with the u-blox SARA, LISA and TOBY cellular module families, facilitating a seamless drop-in migration from other u-blox LPWA, GSM/GPRS, CDMA, UMTS/HSPA and LTE modules. Detailed comparisons and guidelines for the migration between u-blox SARA, LARA, LISA, and TOBY modules are provided in the Nested design application note [3].

1.2 Product features

Table 1 summarizes the main features and interfaces of the u-blox LARA-R2 series, LARA-R6 series, LARA-L6 series and LENA-R8 series modules. Some features are not supported by older product versions of the LARA-R2 series product variant. For more details, see LARA-R2 series data sheet [1].

Model	Region	Radio Access Technology					Positioning	Interfaces	Features	Grade
		LTE Category	LTE FDD bands	LTE TDD bands	3G bands	2G bands	Integrated GNSS receiver External GNSS control AssistNow Software CellLocate®	UART USB 2.0 I2C GPIOs Digital audio	VoLTE CSFB Rx Diversity MIMO 2x2 Dual stack IPv4 / IPv6 TCP/IP, UDP/IP, HTTP/FTP TLS/DTLS MQTT LwM2M FOAT / FOA Device and Data Security 3GPP Power Saving Mode eDRX Last gasp Network indication Antenna detection Antenna dynamic tuning Jamming detection	Standard Professional Automotive
LARA-R202	North America	1	2,4,5,12	2,5			• • • •	2 1 1 9 •	•	
LARA-R203	North America	1	2,4,12				• • • •	2 1 1 9 •	•	
LARA-R204	North America	1	4,13					1 1 1 9 •	•	
LARA-R211	EMEA	1	3,7,20		Dual		• • • •	2 1 1 9 •	•	
LARA-R220	Japan	1	1,19				• • • •	1 1 1 9 •	•	
LARA-R280	APAC	1	3,8,28	1			• • • •	1 1 1 9 •	•	
LARA-R281	EMEA	1	1,3,8 20,28	1			• • • •	1 1 1 9 •	•	
LARA-R6001	Global	1	1,2,3,4,5,7,8 12,13,18,19 20,26,28	38,39 1,2 40,41 5,8	Quad		• • • •	2 1 1 9 •	•	
LARA-R6001D	Global	1	1,2,3,4,5,7,8 12,13,18,19 20,26,28	38,39 1,2 40,41 5,8	Quad		• • • •	2 1 1 9 •	•	
LARA-R6401	North America	1	2,4,5,12,13,14 66,71				• • • •	2 1 1 9 •	•	
LARA-R6401D	North America	1	2,4,5,12,13,14 66,71				• • • •	2 1 1 9 •	•	
LARA-R6801	Multi Region	1	1,2,3,4,5,7,8 18,19,20,26,28	1,2 5,8	Quad		• • • •	2 1 1 9 •	•	
LARA-R6801D	Multi Region	1	1,2,3,4,5,7,8 18,19,20,26,28	1,2 5,8	Quad		○ ○ ○ ○	2 1 1 9 •	○	
LARA-L6004	Global	4	1,2,3,4,5,7,8 12,13,18,19 20,26,28	38,39 1,2 40,41 5,8	Quad		• • • •	2 1 1 9 •	•	
LARA-L6004D	Global	4	1,2,3,4,5,7,8 12,13,18,19 20,26,28	38,39 1,2 40,41 5,8	Quad		• • • •	2 1 1 9 •	•	
LARA-L6804D	Multi Region	4	1,2,3,4,5,7,8 18,19,20,26,28	1,2 5,8	Quad		○ ○ ○ ○	2 1 1 9 •	○	
LENA-R8001	Global	1bis	1,2,3,4,5,7,8 12,20,28,66	38 40,41	Quad		• • • •	1 1 1 6 ■ ■ •	•	
LENA-R8001M10	Global	1bis	1,2,3,4,5,7,8 12,20,28,66	38 40,41	Quad		• • • •	2 1 6 ■ ■ •	•	

• = available with current product version ○ = available with "01B" product version ■ = voice call setup supported without audio

Table 1: LARA / LENA main features summary

As shown in [Table 1](#), LARA-R2, LARA-R6, LARA-L6 and LENA-R8 series include the following modules:

- LARA-R2 series region-specific LTE Cat 1 / 3G / 2G modules:
 - LARA-R202, data and voice product designed mainly for operation in America, supporting four LTE Cat 1 FDD bands plus two 3G bands
 - LARA-R203, data and voice product designed for operation in North America, supporting three LTE Cat 1 FDD bands
 - LARA-R204, data-only product designed for operation in USA, supporting two Verizon LTE Cat 1 FDD bands
 - LARA-R211, data and voice product designed mainly for operation in EMEA, supporting three LTE Cat 1 FDD bands plus two 2G bands
 - LARA-R220, data-only product designed for operation in Japan, supporting two DoCoMo LTE Cat 1 FDD bands
 - LARA-R280, data and voice product designed mainly for operation in APAC, supporting three LTE Cat 1 FDD bands plus one 3G band
 - LARA-R281, data and voice product designed mainly for operation in EMEA, supporting five LTE Cat 1 FDD bands plus one 3G band
- LARA-R6 series global and multi-region LTE Cat 1 / 3G / 2G modules:
 - LARA-R6001, data and voice product designed for world-wide operation, supporting eighteen LTE Cat 1 FDD / TDD bands, four 3G bands and four 2G bands for global coverage
 - LARA-R6001D, data-only product designed for world-wide operation, supporting eighteen LTE Cat 1 FDD / TDD bands, four 3G bands and four 2G bands for global coverage
 - LARA-R6401, data and voice product designed mainly for operation in America, supporting eight LTE Cat 1 FDD bands
 - LARA-R6401D, data-only product designed mainly for operation in America, supporting eight LTE Cat 1 FDD bands
 - LARA-R6801, data and voice product designed for multi-regional operation, in EMEA, APAC, Japan and Latin America, supporting 12 LTE Cat 1 bands, four 3G bands and four 2G bands
 - LARA-R6801D, data-only product designed for multi-regional operation, in EMEA, APAC, Japan and Latin America, supporting 12 LTE Cat 1 bands, four 3G bands and four 2G bands
- LARA-L6 series global and multi-region LTE Cat 4 / 3G / 2G modules pin-to-pin compatible with LARA-R6 modules:
 - LARA-L6004, data and voice product designed for world-wide operation, supporting eighteen LTE Cat 4 FDD / TDD bands plus four 3G bands and four 2G bands for global coverage
 - LARA-L6004D, data-only product designed for world-wide operation, supporting eighteen LTE Cat 4 FDD / TDD bands plus four 3G bands and four 2G bands for global coverage
 - LARA-L6804D, data-only product designed for multi-regional operation, in EMEA, APAC, Japan and Latin America, supporting 12 LTE Cat 4 bands, four 3G bands and four 2G bands
- LENA-R8 series global LTE Cat 1 bis / 2G modules:
 - LENA-R8001, designed for world-wide operation, supporting 14 LTE Cat 1bis FDD / TDD bands and four 2G bands for global coverage
 - LENA-R8001M10, designed for world-wide operation, supporting 14 LTE Cat 1bis FDD / TDD bands and four 2G bands for global coverage, and supporting also GNSS positioning with the integrated ultra-low-power u-blox M10 standard precision concurrent GNSS receiver. The cellular and GNSS are independent subsystems of the module, internally interconnected by dedicated I2C interface, with separate supply inputs and separate interfaces for great usage flexibility, as each subsystem can be operated fully independently

LARA-R2, LARA-R6, LARA-L6 and LENA-R8 modules support the cellular RF bands as summarized in [Table 2](#), with LTE, 3G and 2G characteristics summarized in [Table 3](#), [Table 4](#) and [Table 5](#).

Module	Region	LTE FDD bands	LTE TDD bands	3G bands	2G bands
LARA-R202	North America	12 (700 MHz) 5 (850 MHz) 4 (1700 MHz) 2 (1900 MHz)		5 (850 MHz) 2 (1900 MHz)	
LARA-R203	North America	12 (700 MHz) 4 (1700 MHz) 2 (1900 MHz)			
LARA-R204	North America	13 (700 MHz) 4 (1700 MHz)			
LARA-R211	Europe, Middle East, Africa	20 (800 MHz) 3 (1800 MHz) 7 (2600 MHz)			E-GSM 900 DCS 1800
LARA-R220	Japan	19 (800 MHz) 1 (2100 MHz)			
LARA-R280	Asia-Pacific	28 (700 MHz) 8 (900 MHz) 3 (1800 MHz)		1 (2100 MHz)	
LARA-R281	Europe, Middle East, Africa	28 (700 MHz) 20 (800 MHz) 8 (900 MHz) 3 (1800 MHz) 1 (2100 MHz)		1 (2100 MHz)	
LARA-R6001	Global	12 (700 MHz)	39 (1900 MHz)	5 (850 MHz)	GSM 850
LARA-R6001D		28 (700 MHz)	40 (2300 MHz)	8 (900 MHz)	E-GSM 900
LARA-L6004		13 (700 MHz)	41 (2600 MHz)	2 (1900 MHz)	DCS 1800
LARA-L6004D		20 (800 MHz)	38 (2600 MHz)	1 (2100 MHz)	PCS 1900
		18 (800 MHz) 19 (800 MHz) 26 (850 MHz) 5 (850 MHz) 8 (900 MHz) 4 (1700 MHz) 3 (1800 MHz) 2 (1900 MHz) 1 (2100 MHz) 7 (2600 MHz)			
LARA-R6401	North America	71 (600 MHz)			
LARA-R6401D		12 (700 MHz) 13 (700 MHz) 14 (700 MHz) 5 (850 MHz) 4 (1700 MHz) 66 (1700 MHz) 2 (1900 MHz)			
LARA-R6801	Europe, Middle East, Africa	28 (750 MHz)		5 (850 MHz)	GSM 850
LARA-R6801D	Asia-Pacific	20 (800 MHz)		8 (900 MHz)	E-GSM 900
LARA-L6804D	Japan	18 (800 MHz)		2 (1900 MHz)	DCS 1800
	Latin America	19 (800 MHz) 26 (850 MHz) 5 (850 MHz) 8 (900 MHz) 4 (1700 MHz) 3 (1800 MHz) 2 (1900 MHz) 1 (2100 MHz) 7 (2600 MHz)		1 (2100 MHz)	PCS 1900
LENA-R8001	Global	12 (700 MHz)	40 (2300 MHz)		GSM 850
LENA-R8001M10		28 (700 MHz) 20 (800 MHz) 5 (850 MHz) 8 (900 MHz) 4 (1700 MHz) 66 (1700 MHz) 3 (1800 MHz) 2 (1900 MHz) 1 (2100 MHz) 7 (2600 MHz)	41 (2600 MHz) 38 (2600 MHz)		E-GSM 900 DCS 1800 PCS 1900

Table 2: LARA-R2, LARA-R6, LARA-L6 and LENA-R8 modules cellular RF bands summary

Module	Category	Access	Receiver	Power class	Data Rate
LARA-R2 series	1	FDD	Rx diversity	Class 3 (23 dBm)	up to 10.3 Mbit/s DL, up to 5.2 Mbit/s UL
LARA-R6001 LARA-R6001D	1	FDD, TDD	Rx diversity	Class 3 (23 dBm)	up to 10.3 Mbit/s DL, up to 5.2 Mbit/s UL
LARA-R6401 LARA-R6401D LARA-R6801 LARA-R6801D	1	FDD	Rx diversity	Class 3 (23 dBm)	up to 10.3 Mbit/s DL, up to 5.2 Mbit/s UL
LARA-L6004 LARA-L6004D	4	FDD, TDD	Rx diversity MIMO 2x2	Class 3 (23 dBm)	up to 150 Mbit/s DL, up to 50 Mbit/s UL
LARA-L6804D	4	FDD	Rx diversity MIMO 2x2	Class 3 (23 dBm)	up to 150 Mbit/s DL, up to 50 Mbit/s UL
LENA-R8 series	1bis	FDD, TDD	Single	Class 3 (23 dBm)	up to 10.3 Mbit/s DL, up to 5.2 Mbit/s UL

Table 3: LARA-R2, LARA-R6, LARA-L6 and LENA-R8 modules LTE characteristics summary

Module	Category	Access	Receiver	Power class	Data Rate
LARA-R202 LARA-R280 LARA-R281	HSDPA cat 8 HSUPA cat 6	FDD	Rx diversity	Class 3 (24 dBm)	up to 7.2 Mbit/s DL, up to 5.76 Mbit/s UL
LARA-R203 LARA-R204 LARA-R211 LARA-R220	-	-	-	-	-
LARA-R6001 LARA-R6001D LARA-R6801 LARA-R6801D	HSDPA cat 8 HSUPA cat 6	FDD	Rx diversity	Class 3 (24 dBm)	up to 7.2 Mbit/s DL, up to 5.76 Mbit/s UL
LARA-R6401 LARA-R6401D	-	-	-	-	-
LARA-L6 series	HSDPA cat 24 HSUPA cat 6	FDD	Rx diversity	Class 3 (24 dBm)	up to 42.2 Mbit/s DL, up to 5.76 Mbit/s UL
LENA-R8 series	-	-	-	-	-

Table 4: LARA-R2, LARA-R6, LARA-L6 and LENA-R8 modules 3G characteristics summary

Module	Multi-Slot class	Access	Receiver	Power class	Data Rate
LARA-R211	GPRS class 33 EDGE class 33	TDMA	DARP Phase 1	GPRS Class 4 (33 dBm) for 900 band GPRS Class 1 (30 dBm) for 1800 band EDGE Class E2 (27 dBm) in 900 band EDGE Class E2 (26 dBm) in 1800 band	up to 296 kbit/s DL, up to 236.8 kbit/s UL
LARA-R202 LARA-R203 LARA-R204 LARA-R220 LARA-R280 LARA-R281	-	-	-	-	-
LARA-R6001 LARA-R6001D LARA-R6801 LARA-R6801D LARA-L6 series	GPRS class 33 EDGE class 33	TDMA	DARP Phase 1	GPRS Class 4 (33 dBm) for 800/900 GPRS Class 1 (30 dBm) for 1800/1900 EDGE Class E2 (27 dBm) in 800/900 EDGE Class E2 (26 dBm) in 1800/1900	up to 296 kbit/s DL, up to 236.8 kbit/s UL
LARA-R6401 LARA-R6401D	-	-	-	-	-
LENA-R8 series	GPRS class 12	TDMA	DARP Phase 1	GPRS Class 4 (33 dBm) for 800/900 GPRS Class 1 (30 dBm) for 1800/1900	up to 85.6 kbit/s DL, up to 85.6 kbit/s UL

Table 5: LARA-R2, LARA-R6, LARA-L6 and LENA-R8 modules 2G characteristics summary

2 Migration between LARA and LENA modules

2.1 Overview

The LARA form factor (26 x 24 mm, 100-pin LGA) and LENA form factor (30 x 27 mm, 100-pin LGA) have exactly the same footprint, with compatible pin assignments described in [Figure 1](#), therefore the modules can be alternatively mounted on a single application PCB using exactly the same copper, solder resist and paste mask. The LENA form factor is only slightly wider than the LARA form factor.

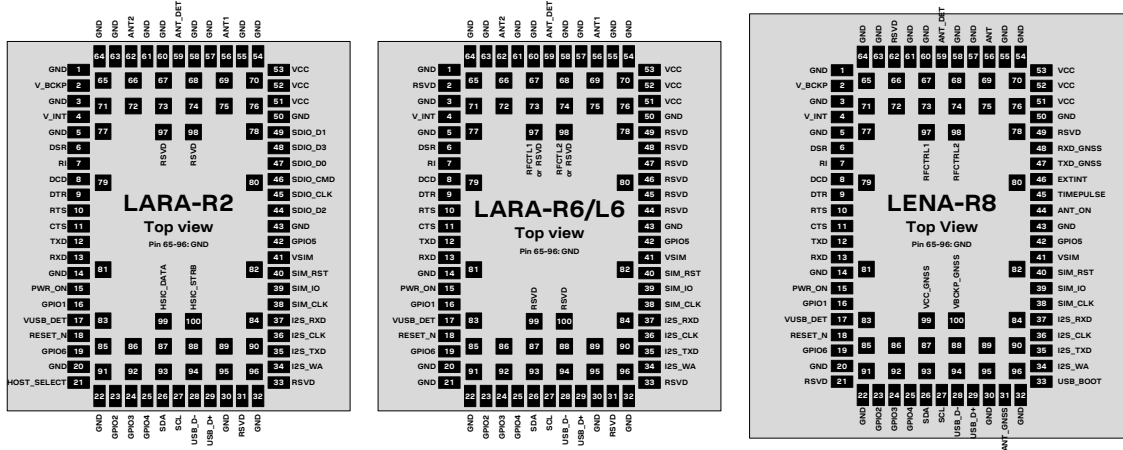

Figure 1: LARA-R2, LARA-R6, LARA-L6 and LENA-R8 series modules' layout and pinout

Table 6 summarizes the interfaces supported by LARA and LENA modules:

	LARA-R2 series	LARA-R6/L6 series	LENA-R8 series
VCC module supply input	•	•	•
V_INT 1.8V supply output	•	•	•
V_BCKP RTC supply input/output	•	•	•
ANT1 primary RF input/output	•	•	•
ANT2 secondary RF input	•	•	•
ANT_DET antenna detection input	•	•	•
Antenna dynamic tuning		• ¹	
PWR_ON input	•	•	•
RESET_N input	•	•	•
SIM interface	•	•	•
SIM detection	•	•	•
Main primary 8-wire UART	•	•	•
Auxiliary secondary 4-wire UART	•	•	• ²
Auxiliary secondary 2-wire UART	•		
USB High-Speed Interface	•	•	•
I2C interface	•	•	• ³
Digital Audio Interface	•	• ⁴	
Clock output	•	• ⁴	
GPIOs	•	•	•
GNSS RF, supply, UART, PIO interfaces			• ⁵

Table 6: Interfaces supported by LARA-R2, LARA-R6, LARA-L6 and LENA-R8 series modules

¹ Antenna dynamic tuning is supported only by LARA-R6401, LARA-R6401D, and all LARA-R6/L6 modules "01B" versions.
² The support of the auxiliary UART interface is not presented with the "OOC" product version of LENA-R8 modules.
³ The support of the external I2C interface is not presented with the "OOC" product version of LENA-R8001M10 modules.
⁴ Audio and clock output are supported only by LARA-R6001, LARA-R6401, LARA-R6801 and LARA-L6004 modules.
⁵ GNSS RF, supply, UART and PIO digital interfaces are supported only by LENA-R8001M10 modules.

The LARA and LENA modules are also form-factor compatible with the u-blox SARA, LISA, and TOBY cellular module families: although each has a different form factor, the footprints for the TOBY, LISA, SARA, LARA, and LENA modules have been developed to ensure layout compatibility.

With the u-blox “nested design” solution, any TOBY, LISA, SARA, LARA, or LENA module can be alternatively mounted on the same space of a single “nested” application PCB as shown in [Figure 2](#), enabling straightforward development of products supporting different radio access technologies.

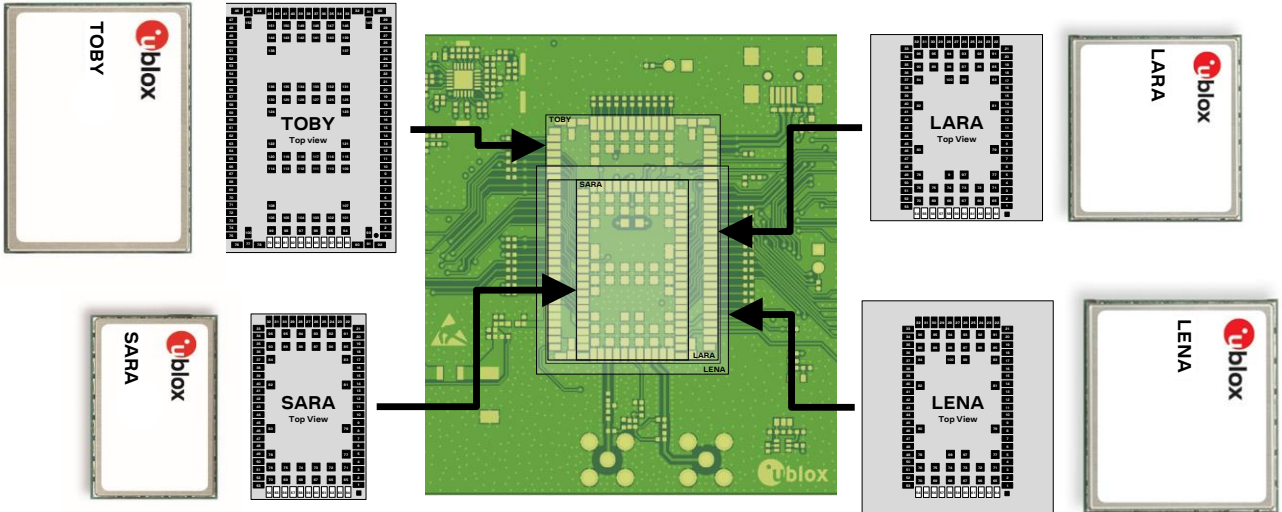

Figure 2: Cellular modules layout compatibility: all modules can be mounted on the same nested footprint

In details, as described in [Figure 3](#), a different top-side stencil (paste mask) is needed for each u-blox module form factor (TOBY, LISA, SARA and LARA/LENA) to be alternatively mounted on the same space of a single “nested” application board.

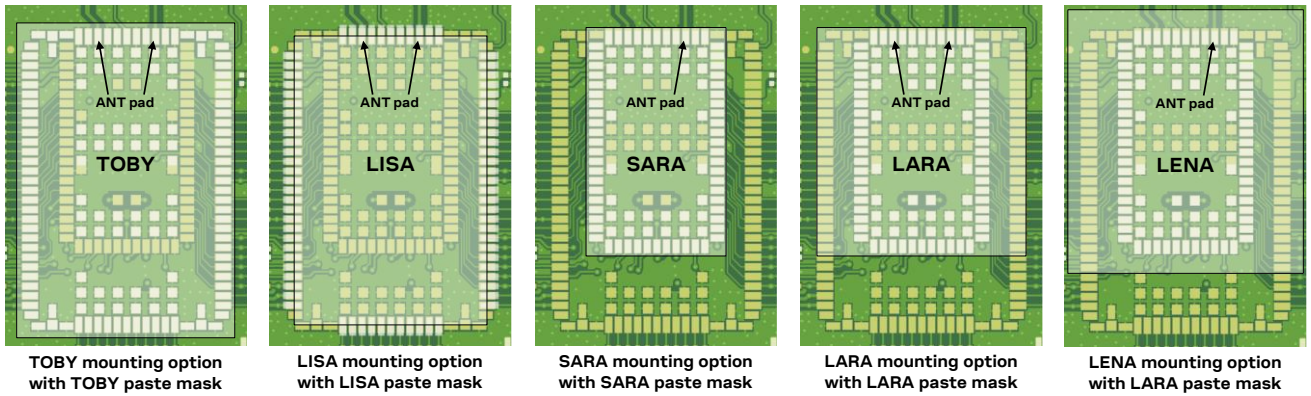

Figure 3: Stencil (paste mask) designs to alternatively mount TOBY, LISA, SARA, LARA and LENA modules on the same PCB

Detailed guidelines to implement a nested application board, a comprehensive description of the u-blox reference nested design and detailed comparisons between the u-blox LARA, SARA, LISA, and TOBY modules are provided in the Nested design application note [\[3\]](#).

2.2 Pin-out comparison between LARA and LENA modules

Table 7 shows a pin-out comparison between LARA-R2, LARA-R6 / LARA-L6, and LENA-R8 modules.

No	LARA-R2 series	LARA-R6 and LARA-L6 series	LENA-R8 series
1	GND Ground	GND Ground	GND Ground
2	V_BCKP RTC supply I/O	RSVD Reserved for future use. Internally not connected.	V_BCKP RTC supply I/O
3	GND Ground	GND Ground	GND Ground
4	V_INT 1.8 V (typical) supply output Generated by DC/DC regulator, when the module is turned on. Test point recommended	V_INT 1.8 V (typical) supply output Generated by LDO linear regulator, when the module is turned on. Test point recommended	V_INT 1.8 V (typical) supply output Generated by LDO linear regulator, when the module is turned on. Test point recommended
5	GND Ground	GND Ground	GND Ground
6	DSR Main UART Data Set Ready output (push-pull, idle high, active low) V_INT voltage supply domain (1.8 V) Output driver strength: 6 mA Internal active pull-up: ~7.5 kΩ	DSR Main UART Data Set Ready output (push-pull, idle high, active low) Alternative function: Auxiliary UART HW flow control input (idle high, active low, with internal active pull-up enabled). V_INT voltage supply domain (1.8 V) Output driver strength: 2 mA Internal active pull-up: ~100 kΩ	DSR Main UART Data Set Ready output (push-pull, idle high, active low) Alternative function ⁶ : Auxiliary UART HW flow control input (idle high, active low, with internal active pull-up enabled). V_INT voltage supply domain (1.8 V) Output driver strength: 2 mA Internal active pull-up: ~20 kΩ
7	RI Main UART Ring Indicator output (push-pull, idle high, active low) V_INT voltage supply domain (1.8 V) Output driver strength: 6 mA	RI Main UART Ring Indicator output (push-pull, idle high, active low) Alternative function: Auxiliary UART HW flow control output (push-pull, idle high, active low). V_INT level (1.8 V) Output driver strength: 2 mA	RI Main UART Ring Indicator output (push-pull, idle high, active low) Alternative function ⁶ : Auxiliary UART HW flow control output (push-pull, idle high, active low). V_INT level (1.8 V) Output driver strength: 2 mA
8	DCD Main UART Data Carrier Detect output (push-pull, idle high, active low) V_INT voltage supply domain (1.8 V) Output driver strength: 6 mA	DCD Main UART Data Carrier Detect output (push-pull, idle high, active low) Alternative function: Auxiliary UART data output (push-pull, idle high, active low). V_INT voltage supply domain (1.8 V) Output driver strength: 2 mA	DCD Main UART Data Carrier Detect output (push-pull, idle high, active low) Alternative function ⁶ : Auxiliary UART data output (push-pull, idle high, active low). V_INT voltage supply domain (1.8 V) Output driver strength: 2 mA
9	DTR Main UART Data Terminal Ready input (idle high, active low, with internal active pull-up enabled) to be set low to activate the greeting text. V_INT voltage supply domain (1.8 V) Internal active pull-up: ~7.5 kΩ	DTR Main UART Data Terminal Ready input (idle high, active low, with internal active pull-up enabled) to be set low to activate the greeting text. Alternative function: Auxiliary UART data input (idle high, active low, with internal active pull-up enabled). V_INT voltage supply domain (1.8 V) Internal active pull-up: ~100 kΩ	DTR Main UART Data Terminal Ready input (idle high, active low, with internal active pull-up enabled) to be set low to activate the greeting text. Alternative function ⁶ : Auxiliary UART data input (idle high, active low, with internal active pull-up enabled). V_INT voltage supply domain (1.8 V) Internal active pull-up: ~20 kΩ

⁶ The support of the auxiliary UART interface is not presented with the “00C” product version of LENA-R8 modules.

No	LARA-R2 series	LARA-R6 and LARA-L6 series	LENA-R8 series
10	RTS Main UART HW flow control input (idle high, active low, with internal active pull-up enabled) V_INT voltage supply domain (1.8 V) Internal active pull-up: ~7.5 kΩ	RTS Main UART HW flow control input (idle high, active low, with internal active pull-up enabled) V_INT voltage supply domain (1.8 V) Internal active pull-up: ~100 kΩ	RTS Main UART HW flow control input (idle high, active low, with internal active pull-up enabled) V_INT voltage supply domain (1.8 V) Internal active pull-up: ~20 kΩ
11	CTS Main UART HW flow control output (push-pull, idle high, active low). V_INT voltage supply domain (1.8 V) Output driver strength: 6 mA	CTS Main UART HW flow control output (push-pull, idle high, active low). V_INT voltage supply domain (1.8 V) Output driver strength: 2 mA	CTS Main UART HW flow control output (push-pull, idle high, active low). V_INT voltage supply domain (1.8 V) Output driver strength: 2 mA
12	TXD Main UART data input (idle high, active low, with internal active pull-up enabled). V_INT voltage supply domain (1.8 V) Internal active pull-up: ~7.5 kΩ	TXD Main UART data input (idle high, active low, with internal active pull-up enabled). V_INT voltage supply domain (1.8 V) Internal active pull-up: ~100 kΩ	TXD Main UART data input (idle high, active low, with internal active pull-up enabled). V_INT voltage supply domain (1.8 V) Internal active pull-up: ~20 kΩ
13	RXD Main UART data output (push-pull, idle high, active low). V_INT voltage supply domain (1.8 V) Output driver strength: 6 mA	RXD Main UART data output (push-pull, idle high, active low). V_INT voltage supply domain (1.8 V) Output driver strength: 2 mA	RXD Main UART data output (push-pull, idle high, active low). V_INT voltage supply domain (1.8 V) Output driver strength: 2 mA
14	GND Ground	GND Ground	GND Ground
15	PWR_ON Power-on/off input (idle high, active low, with 10 kΩ internal pull-up). V_BCKP voltage supply domain L-level: -0.30 ÷ 0.54 V L-level pulse time to start switch on: 50 μs min L-level pulse time to start switch off: 1.0 s min No external pull-up to be connected Test point recommended	PWR_ON Power-on/off input (idle high, active low, with ~200 kΩ internal pull-up). Internal voltage supply domain L-level: -0.30 ÷ 0.35 V L-level pulse time to start switch on: 0.15 s min ÷ 3.2 s max L-level pulse time to start switch off: 1.5 s min No external pull-up to be connected Test point recommended	PWR_ON Power-on/off input (idle high, active low, with ~20 kΩ internal pull-up). VCC voltage supply domain L-level: -0.30 ÷ 0.50 V L-level pulse time to start switch on: 2.0 s min L-level pulse time to start switch off: 3.1 s min No external pull-up to be connected Test point recommended
16	GPIO1 GPIO configurable as Input, Output, Network status indication output, external GNSS supply enable output. Default: tri-stated with pull-down. V_INT voltage supply domain (1.8 V) Push-pull output type. Output driver strength: 6 mA Internal active pull-up: ~17 kΩ	GPIO1 GPIO configurable as Input, Output, Network status indication output, external GNSS supply enable output. Default: tri-stated with pull-down. V_INT voltage supply domain (1.8 V) Push-pull output type. Output driver strength: 2 mA Internal active pull-up/down: ~100 kΩ	GPIO1 GPIO configurable as Input, Output, Network status indication output, GNSS supply enable output. Default: tri-stated with pull-down. V_INT voltage supply domain (1.8 V) Push-pull output type. Output driver strength: 2 mA Internal active pull-up/down: ~20/50kΩ
17	VUSB_DET 5 V sense input to detect USB host and enable the USB. H-level: 1.5 ÷ 5.25 V Test point highly recommended	VUSB_DET 5 V sense input present at boot to detect USB host and enable the USB H-level: 1.5 ÷ 5.25 V Test point highly recommended	VUSB_DET 5 V sense input to detect USB host and enable the USB H-level: 4.5 ÷ 5.25 V Test point highly recommended

No	LARA-R2 series	LARA-R6 and LARA-L6 series	LENA-R8 series
18	RESET_N Abrupt emergency reset input (idle high, active low, with 10 kΩ internal pull-up). V_BCKP voltage supply domain L-level: -0.30 ÷ 0.54 V L-level time to trigger abrupt reboot: 50 ms min Test point recommended	RESET_N Abrupt emergency reset input (idle high, active low, with ~37 kΩ internal active pull-up). Internal voltage supply domain L-level: -0.30 ÷ 0.63 V L-level time to start graceful reboot: 50 ms min ÷ 6 s max L-level time to start abrupt switch off: 10 s min Test point recommended	RESET_N Abrupt emergency reset input (idle high, active low, with ~17 kΩ internal active pull-up). VCC voltage supply domain L-level: -0.30 ÷ 0.50 V L-level time to trigger abrupt reboot: 50 ms min Test point recommended
19	GPIO6 13 or 26 MHz clock output. Default: tri-stated with pull-down. V_INT voltage supply domain (1.8 V) Push-pull output type. Driver strength: 4 mA Internal active pull-down: ~7.5 kΩ	GPIO6 12.288 MHz clock output ⁷ . Default: tri-stated with pull-down. V_INT voltage supply domain (1.8 V) Push-pull output type. Output driver strength: 2 mA Internal active pull-down: ~100 kΩ	GPIO6 GPIO configurable as Input, Output. Default: tri-stated with pull-down. V_INT voltage supply domain (1.8 V) Push-pull output type. Output driver strength: 2 mA Internal active pull-up/down: ~20/50kΩ
20	GND Ground	GND Ground	GND Ground
21	HOST_SELECT Selection of module / host processor configuration function not supported Default: tri-stated with pull-down. V_INT voltage supply domain (1.8 V) Internal active pull-up/down: ~7.5 kΩ	GND Ground	RSVD Reserved for future use Internally not connected
22	GND Ground	GND Ground	GND Ground
23	GPIO2 GPIO configurable as Input, Output, Network status indication output, external GNSS supply enable output. Default: output for external GNSS supply enable control V_INT voltage supply domain (1.8 V) Push-pull output type. Output driver strength: 6 mA Internal active pull-up/down: ~7.5 kΩ	GPIO2 GPIO configurable as Input, Output, Network status indication output, external GNSS supply enable output. Default: output for external GNSS supply enable control V_INT voltage supply domain (1.8 V) Push-pull output type. Output driver strength: 2 mA Internal active pull-up/down: ~100 kΩ	GPIO2 GPIO configurable as Input, Output, Network status indication output, GNSS supply enable output. Default: tri-stated with pull-down V_INT voltage supply domain (1.8 V) Push-pull output type. Output driver strength: 2 mA Internal active pull-up/down: ~20/50kΩ
24	GPIO3 GPIO configurable as Input, Output, Network status indication output, external GNSS supply enable output, external GNSS data ready input. Default: GNSS Tx data ready input V_INT voltage supply domain (1.8 V) Push-pull output type. Output driver strength: 6 mA Internal active pull-up/down: ~7.5 kΩ	GPIO3 GPIO configurable as Input, Output, Network status indication output, external GNSS supply enable output, external GNSS data ready input, Last gasp trigger input, Faster and safe power-off trigger input. Default: GNSS Tx data ready input V_INT voltage supply domain (1.8 V) Push-pull output type. Output driver strength: 2 mA Internal active pull-up/down: ~100 kΩ	GPIO3 GPIO configurable as Input, Output, Network status indication output, GNSS supply enable output, external GNSS data ready input ⁸ . Default: tri-stated with pull-down V_INT voltage supply domain (1.8 V) Push-pull output type. Output driver strength: 2 mA Internal active pull-up/down: ~20/50kΩ

⁷ LARA-R6001, LARA-R6401, LARA-R6801 and LARA-L6404 data and voice products only.

⁸ LENA-R8001 only, as the module does not integrate a GNSS receiver.

No	LARA-R2 series	LARA-R6 and LARA-L6 series	LENA-R8 series
25	GPIO4 GPIO configurable as Input, Output, Network status indication output, external GNSS supply enable output. Default: output / low V_INT voltage supply domain (1.8 V) Push-pull output type. Output driver strength: 6 mA Internal active pull-up/down: ~7.5 kΩ	GPIO4 GPIO configurable as Input, Output, Network status indication output, external GNSS supply enable output. Default: output / low V_INT voltage supply domain (1.8 V) Push-pull output type. Output driver strength: 2 mA Internal active pull-up/down: ~100 kΩ	GPIO4 GPIO configurable as Input, Output, Network status indication output, GNSS supply enable output. Default: tri-stated with pull-down V_INT voltage supply domain (1.8 V) Push-pull output type. Output driver strength: 2 mA Internal active pull-up/down: ~20/50kΩ
26	SDA I2C data (open drain, idle high, active low, no internal pull-up). Alternative function: Second auxiliary UART data input (idle high, active low, with internal active pull-up enabled). V_INT voltage supply domain (1.8 V)	SDA I2C data (open drain, idle high, active low, 2.2 kΩ internal pull-up). V_INT voltage supply domain (1.8 V)	SDA I2C data ⁹ (open drain, idle high, active low, ~20 kΩ internal active pull-up). V_INT voltage supply domain (1.8 V)
27	SCL I2C clock (open drain, idle high, active low, no internal pull-up). Alternative function: Second auxiliary UART data output (push-pull, idle high, active low). V_INT voltage supply domain (1.8 V)	SCL I2C clock (open drain, idle high, active low, 2.2 kΩ internal pull-up). V_INT voltage supply domain (1.8 V)	SCL I2C clock ⁹ (open drain, idle high, active low, ~20 kΩ internal active pull-up). V_INT voltage supply domain (1.8 V)
28	USB_D- USB data I/O (D-) High-speed USB 2.0 Test point highly recommended	USB_D- USB data I/O (D-) High-speed USB 2.0 Test point highly recommended	USB_D- USB data I/O (D-) High-speed USB 2.0 Test point highly recommended
29	USB_D+ USB data I/O (D+) High-speed USB 2.0 Test point highly recommended	USB_D+ USB data I/O (D+) High-speed USB 2.0 Test point highly recommended	USB_D+ USB data I/O (D+) High-speed USB 2.0 Test point highly recommended
30	GND Ground	GND Ground	GND Ground
31	RSVD Reserved for future use Internally not connected	RSVD Reserved for future use Internally not connected	ANT_GNSS LENA-R8001M10 only. RF input for GNSS Rx antenna.
32	GND Ground	GND Ground	GND Ground
33	RSVD Reserved use It can be connected to ground	RSVD Reserved use Test point highly recommended	USB_BOOT Input to force FW update over USB. Test point highly recommended
34	I2S_WA I2S Word Alignment input/output, alternatively configurable GPIO. Default: I2S Word Alignment V_INT voltage supply domain (1.8 V) Push-pull output type. Output driver strength: 6 mA Internal active pull-up/down: ~7.5 kΩ	I2S_WA ¹⁰ I2S Word Alignment output, alternatively configurable GPIO. Default: I2S Word Alignment V_INT voltage supply domain (1.8 V) Push-pull output type. Output driver strength: 2 mA Internal active pull-up/down: ~7.5 kΩ	I2S_WA ¹¹ I2S Word Alignment input. Function currently not presented. V_INT voltage supply domain (1.8 V)

⁹ The support of the external I2C interface is not presented with the “00C” product version of LENA-R8001M10 modules.

¹⁰ LARA-R6001, LARA-R6401, LARA-R6801 and LARA-L6404 data and voice products only.

¹¹ The support of the I2S digital audio interface is not presented with the “00C” product version of LENA-R8 modules.

No	LARA-R2 series	LARA-R6 and LARA-L6 series	LENA-R8 series
35	I2S_TXD I2S data output, alternatively configurable GPIO. Default: I2S data output V_INT voltage supply domain (1.8 V) Push-pull output type. Output driver strength: 6 mA Internal active pull-up/down: ~7.5 kΩ	I2S_TXD¹⁰ I2S data output, alternatively configurable GPIO. Default: I2S data output V_INT voltage supply domain (1.8 V) Push-pull output type. Output driver strength: 2 mA Internal active pull-up/down: ~100 kΩ	I2S_TXD¹² I2S data output. Function currently not presented. V_INT voltage supply domain (1.8 V) Push-pull output type. Output driver strength: 2 mA
36	I2S_CLK I2S clock input/output, alternatively configurable GPIO. Default: I2S clock V_INT voltage supply domain (1.8 V) Push-pull output type. Output driver strength: 6 mA Internal active pull-up/down: ~7.5 kΩ	I2S_CLK¹⁰ I2S clock output, alternatively configurable GPIO. Default: I2S clock V_INT voltage supply domain (1.8 V) Push-pull output type. Output driver strength: 2 mA Internal active pull-up/down: ~100 kΩ	I2S_CLK¹² I2S clock input. Function currently not presented. V_INT voltage supply domain (1.8 V)
37	I2S_RXD I2S data input, alternatively configurable GPIO. Default: I2S data input V_INT voltage supply domain (1.8 V) Push-pull output type. Output driver strength: 6 mA Internal active pull-up/down: ~7.5 kΩ	I2S_RXD¹⁰ I2S data input, alternatively configurable GPIO. Default: I2S data input V_INT voltage supply domain (1.8 V) Push-pull output type. Output driver strength: 2 mA Internal active pull-up/down: ~100 kΩ	I2S_RXD¹² I2S data input. Function currently not presented. V_INT voltage supply domain (1.8 V)
38	SIM_CLK Clock output for external 1.8 V / 3 V SIM card/chip	SIM_CLK Clock output for external 1.8 V / 3 V SIM card/chip	SIM_CLK Clock output for external 1.8 V / 3 V SIM card/chip
39	SIM_IO I/O data line for external 1.8 V / 3 V SIM card/chip Internal pull-up: 4.7 kΩ	SIM_IO I/O data line for external 1.8 V / 3 V SIM card/chip Internal pull-up: 4.7 kΩ	SIM_IO I/O data line for external 1.8 V / 3 V SIM card/chip Internal pull-up: 10 kΩ
40	SIM_RST Reset output for external 1.8 V / 3 V SIM card/chip	SIM_RST Reset output for external 1.8 V / 3 V SIM card/chip	SIM_RST Reset output for external 1.8 V / 3 V SIM card/chip
41	VSIM Supply output for external 1.8 V / 3 V SIM card/chip	VSIM Supply output for external 1.8 V / 3 V SIM card/chip	VSIM Supply output for external 1.8 V / 3 V SIM card/chip
42	GPIO5 GPIO configurable as Input, Output, SIM detection input. Default: SIM detection input V_INT voltage supply domain (1.8 V) Push-pull output type. Output driver strength: 6 mA Internal active pull-up/down: ~7.5 kΩ	GPIO5 GPIO configurable as Input, Output, SIM detection input. Default: SIM detection input V_INT voltage supply domain (1.8 V) Push-pull output type. Output driver strength: 2 mA Internal active pull-up/down: ~100 kΩ	GPIO5 GPIO configurable as Input, Output. Default: tri-stated with pull-down V_INT voltage supply domain (1.8 V) Push-pull output type. Output driver strength: 2 mA Internal active pull-up/down: ~20/50kΩ
43	GND Ground	GND Ground	GND Ground
44	SDIO_D2 SDIO serial data [2], not supported Default: tri-stated with pull-down.	RSVD Reserved for future use	ANT_ON LENA-R8001M10 only. External GNSS antenna supply control VCC_GNSS voltage supply domain Push-pull output type. Output driver strength: 2 mA

¹² The support of the I2S digital audio interface is not presented with the “00C” product version of LENA-R8 modules.

No	LARA-R2 series	LARA-R6 and LARA-L6 series	LENA-R8 series
45	SDIO_CLK SDIO serial clock, not supported Default: tri-stated with pull-down.	RSVD Reserved for future use	TIMEPULSE LENA-R8001M10 only. GNSS time pulse output VCC_GNSS voltage supply domain Push-pull output type. Output driver strength: 2 mA
46	SDIO_CMD SDIO command, not supported Default: tri-stated with pull-down.	RSVD Reserved for future use	EXTINT LENA-R8001M10 only. GNSS external interrupt input VCC_GNSS voltage supply domain Internal active pull-up: ~17 kΩ
47	SDIO_D0 SDIO serial data [0], not supported Default: tri-stated with pull-down.	RSVD Reserved for future use	TXD_GNSS LENA-R8001M10 only. GNSS UART data output VCC_GNSS voltage supply domain Push-pull output type. Output driver strength: 2 mA
48	SDIO_D3 SDIO serial data [3], not supported Default: tri-stated with pull-down.	RSVD Reserved for future use	RXD_GNSS LENA-R8001M10 only. GNSS UART data input VCC_GNSS voltage supply domain Internal active pull-up: ~17 kΩ
49	SDIO_D1 SDIO serial data [1], not supported Default: tri-stated with pull-down.	RSVD Reserved for future use	RSVD Reserved for future use
50	GND Ground	GND Ground	GND Ground
51	VCC Supply input for the whole module Normal operating range: 3.3 ÷ 4.4 V Extended operating range: 3.0 ÷ 4.5 V LARA-R211: Supply input for BB PMU part	VCC Supply input for baseband PMU part Normal operating range: 3.3 ÷ 4.5 V Extended operating range: 3.1 ÷ 4.5 V	VCC Supply input for baseband PMU part Normal operating range: 3.4 ÷ 4.2 V Extended operating range: 3.2 ÷ 4.5 V
52	VCC Supply input for the whole module Normal operating range: 3.3 ÷ 4.4 V Extended operating range: 3.0 ÷ 4.5 V LARA-R211: Supply for RF Power Amplifiers part	VCC Supply for RF Power Amplifiers part. Normal operating range: 3.3 ÷ 4.5 V Extended operating range: 2.8 ÷ 4.5 V	VCC Supply for RF Power Amplifiers part. Normal operating range: 3.4 ÷ 4.2 V Extended operating range: 3.0 ÷ 4.5 V
53	VCC Supply input for the whole module Normal operating range: 3.3 ÷ 4.4 V Extended operating range: 3.0 ÷ 4.5 V LARA-R211: Supply for RF Power Amplifiers part	VCC Supply for RF Power Amplifiers part Normal operating range: 3.3 ÷ 4.5 V Extended operating range: 2.8 ÷ 4.5 V	VCC Supply for RF Power Amplifiers part Normal operating range: 3.4 ÷ 4.2 V Extended operating range: 3.0 ÷ 4.5 V
54	GND Ground	GND Ground	GND Ground
55	GND Ground	GND Ground	GND Ground
56	ANT1 RF pin for main Tx / Rx cellular antenna 50 Ω characteristic impedance.	ANT1 RF pin for main Tx / Rx cellular antenna 50 Ω characteristic impedance.	ANT RF pin for Tx / Rx cellular antenna 50 Ω characteristic impedance.
57	GND Ground	GND Ground	GND Ground

No	LARA-R2 series	LARA-R6 and LARA-L6 series	LENA-R8 series
58	GND Ground	GND Ground	GND Ground
59	ANT_DET ADC input pin for antenna detection (optional function)	ANT_DET ADC input pin for antenna detection (optional function)	ANT_DET ADC input pin for antenna detection (optional function)
60	GND Ground	GND Ground	GND Ground
61	GND Ground	GND Ground	GND Ground
62	ANT2 RF pin for secondary Rx diversity cellular antenna 50 Ω nominal characteristic impedance.	ANT2 RF pin for secondary Rx diversity / MIMO cellular antenna 50 Ω nominal characteristic impedance.	RSVD Reserved for future use.
63	GND Ground	GND Ground	GND Ground
...	All pins from 63 to 96 are Ground	All pins from 63 to 96 are Ground	All pins from 63 to 96 are Ground
96	GND Ground	GND Ground	GND Ground
97	RSVD Reserved for future use. Internally not connected.	RSVD ¹³ Reserved for future use RFCTL1 ¹⁴ 1.8 V push-pull output to control an external antenna tuning IC.	RFCTL1 1.8 V push-pull output to control an external antenna tuning IC. Function not supported.
98	RSVD Reserved for future use. Internally not connected.	RSVD ¹³ Reserved for future use RFCTL2 ¹⁴ 1.8 V push-pull output to control antenna tuning IC.	RFCTL2 1.8 V push-pull output to control an external antenna tuning IC. Function not supported.
99	HSIC_DATA HSIC USB not supported.	RSVD Reserved for future use	VCC_GNSS LENA-R8001M10 only. GNSS main supply input
100	HSIC_STRB HSIC USB not supported.	RSVD Reserved for future use	VBCKP_GNSS LENA-R8001M10 only. GNSS backup supply input

Table 7: LARA-R2, LARA-R6, LARA-L6, LENA-R8 series modules pin assignment and description, with remarks for migration

 For further details regarding characteristics, capabilities, usage or settings applicable for each interface of the LARA-R2, LARA-R6, LARA-L6, and LENA-R8 series cellular modules, see the related data sheet [1] [4] [5] [7], system integration manual [2] [6] [8], AT commands manual [9] [10] [11], and the nested design application note [3].

¹³ LARA-R6001, LARA-R6001D, LARA-R6801, LARA-L6004 and LARA-L6004D modules “00B” product version.

¹⁴ LARA-R6401 and LARA-R6401D modules, and any LARA-R6 and LARA-L6 modules “01B” product version.

2.3 Interfaces comparison between LARA and LENA modules

2.3.1 VCC module supply input

LARA-R2, LARA-R6, LARA-L6 and LENA-R8 cellular modules have compatible power requirements, with only minor differences in their **VCC** input voltage ranges and current consumption figures. The same compatible external **VCC** supply circuit can be implemented for all the LARA and LENA cellular modules, like the example described in [Figure 4](#).

The nominal voltage provided at the **VCC** input pins must be within the related normal operating range limits, and the actual voltage during module operations must be held above the minimum limit of the extended operating range to avoid the undervoltage switch-off of the module. For the detailed values of **VCC** input voltage ranges, see [Table 7](#), or the related module's data sheet [\[1\]](#) [\[4\]](#) [\[5\]](#) [\[7\]](#).

The time-division RF transmission of 2G radio access technology can be up to ~2 W, whereas in 3G or LTE radio access technology it is only up to ~0.25 W. Therefore, the pulse current profile in radio connected mode when a data/voice call is enabled may be significantly higher for cellular modules supporting the 2G radio access technology than for modules that do not have 2G fallback.

While selecting and designing the supply source for LARA / LENA cellular modules, consider with adequate safe margin the maximum current consumption of the LARA / LENA cellular module specifically selected, considering the radio access technologies supported by the module.

For the detailed module's current consumption figures, see related module's data sheet [\[1\]](#) [\[4\]](#) [\[5\]](#) [\[7\]](#). For additional specific design guidelines, see the related system integration manual [\[2\]](#) [\[6\]](#) [\[8\]](#).

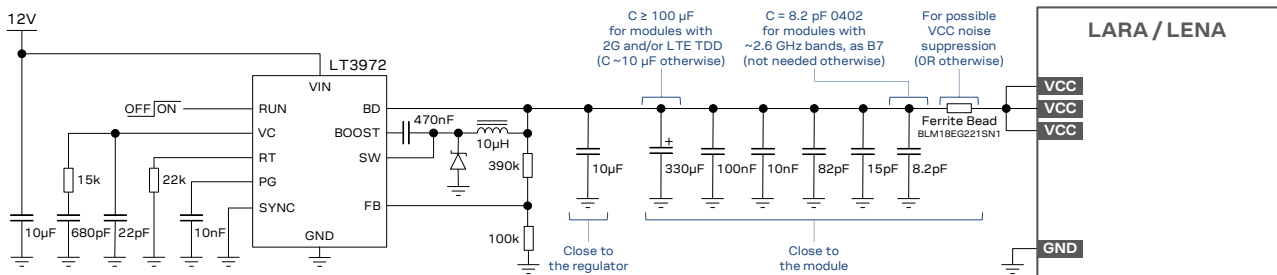

Figure 4: Example of compatible VCC supply application circuit using a high reliability step-down regulator

The **VCC** supply circuit illustrated in [Figure 4](#) includes capacitors with self-resonant frequency in the supported RF cellular bands, to be placed close to the **VCC** pins of the module. The **VCC** line is narrowed down to no wider than the pad of the capacitors, to adequately filter EMI. Additionally, a ferrite bead specifically designed to suppress EMI in the GHz band is placed very close to the **VCC** pins of the module to suppress possible noise from the **VCC** line.

Note that the switch-on sequence of LARA-R2 series can be triggered by applying a valid **VCC** supply, starting a voltage value of less than 2.1 V, and with a fast-rising slope (from 2.3 V to 2.8 V in less than 4 ms) up to the nominal **VCC** voltage within the normal operating range.

Instead, LARA-R6, LARA-L6 and LENA-R8 series cellular modules stay switched off even after a valid **VCC** supply has been applied: the **PWR_ON** input line must be properly toggled low, with valid **VCC** supply present, to trigger the switch-on sequence of these modules.

2.3.2 V_INT 1.8 V supply output

LARA and LENA cellular modules provide a 1.8 V supply output at the same **V_INT** pin, which is internally generated when the cellular module is switched on.

The same voltage domain is used internally to supply the generic digital interfaces of the modules (as the UARTs, I2C, I2S, GPIOs), and therefore we recommend using the **V_INT** supply output to supply the module side of external voltage translators connected to these interfaces of the modules.

We recommend monitoring the status of the **V_INT** output line by an input pin of the external host processor to define when the cellular module is switched on. We also recommend to provide a test point to access the line for diagnostic.

2.3.3 V_BCKP RTC supply input/output

LARA-R2 and LENA-R8 modules provide the cellular RTC supply input/output at the same **V_BCKP** pin, which is not available on LARA-R6 and LARA-L6 modules, having the same pin internally not connected. The **V_BCKP** pin can be left externally unconnected in most of the applications, not requiring the cellular RTC running when the main **VCC** supply is not present.

2.3.4 Cellular RF interfaces

LARA-R2, LARA-R6, LARA-L6 and LENA-R8 cellular modules provide the primary RF input/output line at the same **ANT1 / ANT** pin, which must be connected to a suitable external antenna to transmit and receive cellular RF signals.

LARA-R2, LARA-R6 and LARA-L6 cellular modules provide the secondary RF input line at the same **ANT2** pin, which is to be connected to an antenna to receive cellular RF signals in LTE and 3G radio access technologies implementing the Down-Link Rx diversity / MIMO 2x2 function. This is not available with LENA-R8 series LTE Cat 1bis modules (related **RSVD** pad of LENA-R8 cellular modules can be left unconnected).

The same optional antenna detection circuit can be implemented for LARA-R2, LARA-R6, LARA-L6 and LENA-R8 cellular modules using the same available optional **ANT_DET** input pin.

A compatible external RF circuit can be implemented for all the LARA and LENA cellular modules, as the example illustrated in [Figure 5](#), considering that:

- The antenna matching circuits are to be implemented according to the specific characteristics of the selected antennas.
- An additional low-pass filter with cutoff frequency ~3 GHz is to be considered for the transmitting RF path, to attenuate radiated spurious emissions in the range of frequency higher than the operating one of the module.
- It's not necessary to implement the antenna detection circuit on the PCB where the module is mounted, unless the selected external antenna assembly is equipped with an internal diagnostic resistor, so that the **ANT_DET** input pin can be left unconnected.
- The antenna dynamic tuning feature supported by LARA-R6 and LARA-L6 modules (see section [2.3.13](#)) may not be required for most of the applications, so that the **RFCTL1** and **RFCTL2** pins can be left unconnected.

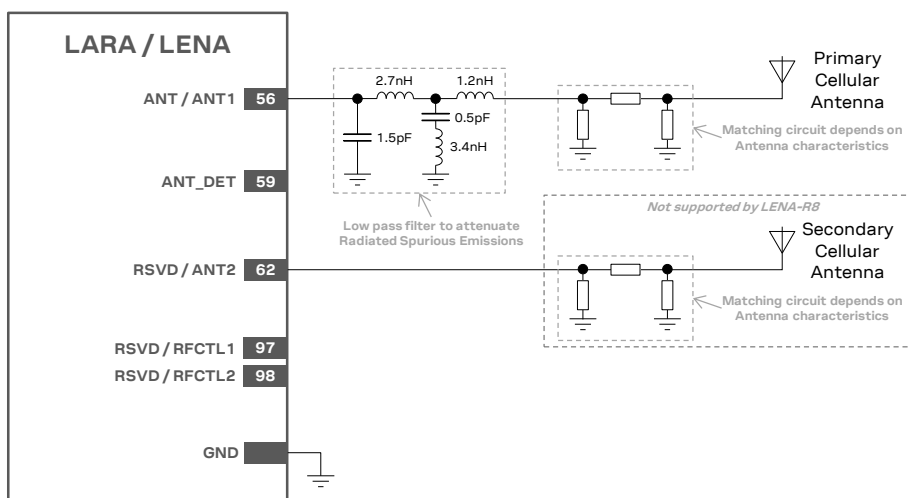

Figure 5: Example of compatible RF application circuit for LARA and LENA modules

While selecting the antenna for LARA and LENA cellular modules, consider the frequency range supported by each LARA and LENA module, as illustrated in Figure 6.

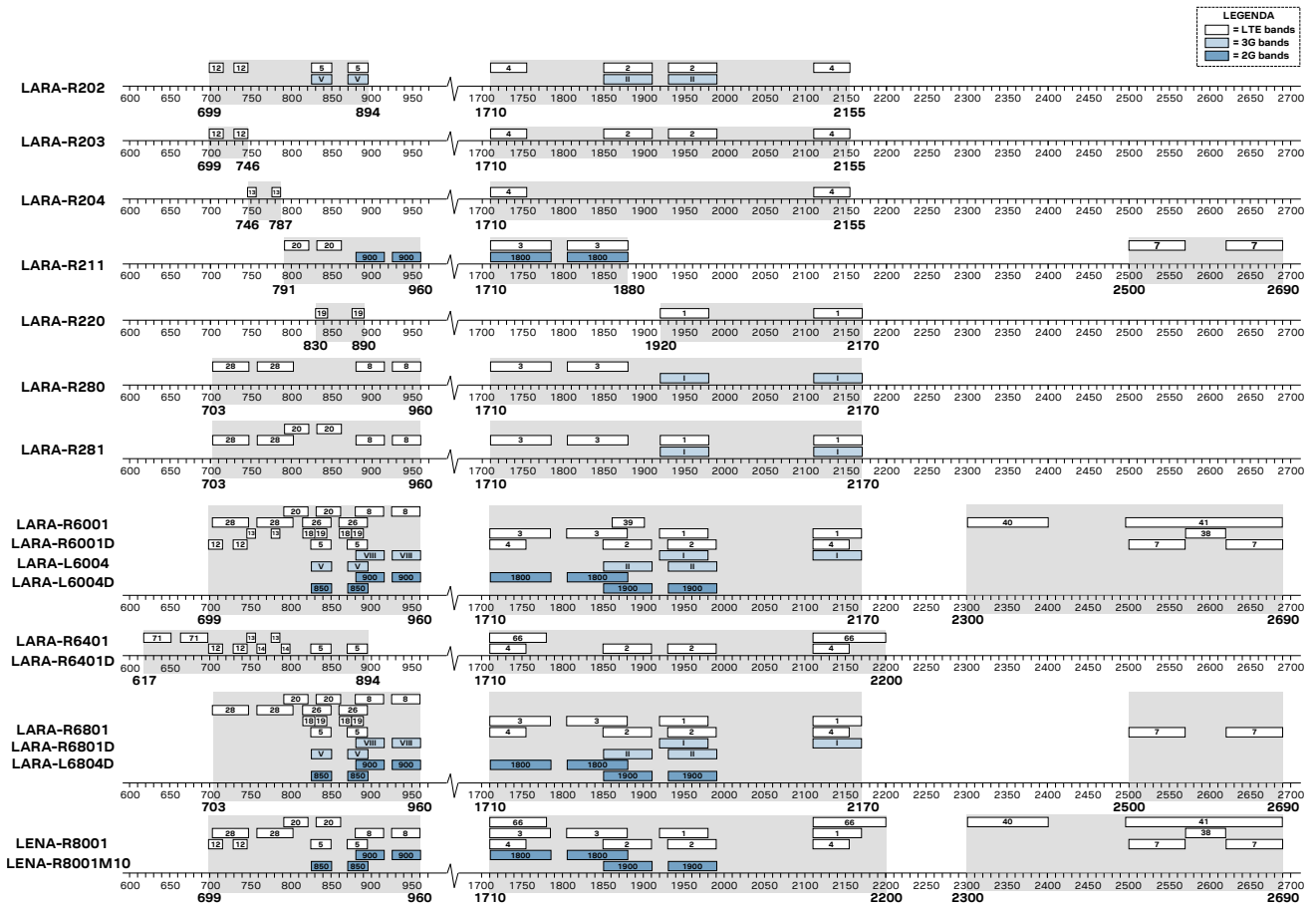

Figure 6: Summary of operating frequency bands supported by LARA and LENA modules

2.3.5 System control interfaces

The **PWR_ON** and the **RESET_N** input lines have internal pull-up resistors on LARA-R2, LARA-R6, LARA-L6 and LENA-R8 cellular modules, and both lines are intended to be driven by external open drain drivers: the same compatible external circuits can be implemented for LARA / LENA modules.

The switch-on sequence of LARA-R2 series modules can be triggered by applying a valid **VCC** power supply (see section 2.3.1), while LARA-R6, LARA-L6 and LENA-R8 cellular modules remain switched off after a valid **VCC** power supply is applied to the modules: the **PWR_ON** input line must be properly toggled low, with valid **VCC** supply present, to trigger the switch-on sequence of the modules.

In particular, with LENA-R8 modules, first a valid voltage at the **VCC** cellular supply input must be applied, then it is necessary to wait at least 1.5 s, and then a low level at the **PWR_ON** input pin can be force to start the switch-on sequence of the LENA-R8 modules cellular system.

The **PWR_ON** input line can be used to trigger the graceful switch-off procedure of the LARA-R2, LARA-R6, LARA-L6 and LENA-R8 cellular modules, as an alternative to using the **+CPWROFF AT** command. Afterwards, the switch-on sequence of the cellular modules can be triggered again by properly toggling low **PWR_ON** input line.

The assertion or toggling of the **RESET_N** input line causes different actions:

- the **RESET_N** line of LARA-R2 series modules triggers an unconditional reboot of the module when toggled, with internal PMU shutdown when set low.

- the **RESET_N** line of LARA-R6 and LARA-L6 series modules triggers an unconditional graceful reboot of the module when set low for a short time period.
- the **RESET_N** line of LARA-R6 and LARA-L6 series modules triggers an unconditional shutdown of the module when set low for a long time period.
- the **RESET_N** line of LENA-R8 series modules triggers an unconditional reboot of the cellular module when toggled.

The timings for proper control of the **PWR_ON** and **RESET_N** input lines of the cellular modules are reported in the related module's data sheet [1] [4] [5] [7].

It is recommended to provide test points on the **PWR_ON** and **RESET_N** input lines, to trigger the FW update procedure, and for diagnostic purpose.

2.3.6 SIM interface

The same compatible external SIM circuit can be implemented for LARA and LENA cellular modules: external 1.8 V and 3.0 V SIM card / IC are supported over the available standardized SIM interface over the same **VSIM**, **SIM_IO**, **SIM_CLK**, **SIM_RST** pins.

The same optional SIM detection circuit can be implemented for LARA cellular modules using the same available **GPIO5** pin. The SIM detection function is not supported by LENA-R8 modules.

2.3.7 UART interfaces

Primary UART interface

LARA and LENA cellular modules provide a compatible primary 8-wire 1.8 V UART interface including:

- data lines (the same **RXD** output and **TXD** input pins),
- hardware flow control lines (the same **CTS** output and **RTS** input pins),
- modem status and control lines (the same **DTR** input, **DSR** output, **DCD** output and **RI** output pins)

The LARA-R2, LARA-R6 and LARA-L6 modules support AT commands and data communication, multiplexer functionality including virtual channel for GNSS tunneling, and FW update by FOAT on the primary UART interface.

The LENA-R8 series cellular modules support AT commands and data communication, multiplexer functionality, and FW update by means of FOAT on the main primary UART interface.

Additionally, LARA-R2 series modules support the FW update by the u-blox EasyFlash tool, and the diagnostic trace logging functions over the primary UART interface.

We recommend providing test points on **RXD** and **TXD** pins, and 0 Ω series jumpers to detach the lines from the external host processor, for FW update of LARA-R2 modules and for diagnostic.

The primary UART interfaces of LARA and LENA cellular modules are electrically compatible, so that the same compatible external circuit can be used. However, we recommend checking the possible differences in the strength of the internal pull-ups at the inputs of the modules if open-drain drivers or voltage dividers are used in the external circuit. We recommend using unidirectional push-pull drivers for unidirectional push-pull interfaces as the UART is, using the **V_INT** output to supply the module side of external voltage translators connected to the UART interfaces of the cellular modules.

The baud rates and configurations available and supported by the cellular modules for the primary UART interface may slightly differ:

- LARA-R2 series modules have the one-shot automatic baud rate and frame format detection available by default, and they support high-speed UART data rates up to 6.5 Mbit/s.
- LARA-R6 and LARA-L6 series modules have the 115,200 bit/s baud rate and the 8N1 frame format available by default, and they support high-speed UART data rates up to 3.0 Mbit/s.
- LENA-R8 series modules have the one-shot automatic baud rate detection with 8N1 frame format available by default (LENA-R8 module uses the first AT command to detect the current baud rate, meaning that the first command is not executed and will not provide neither echo nor response), and they support UART data rates up to 921,600 bit/s.

For more details about UART settings, see related module's AT commands manual [\[9\]](#) [\[10\]](#) [\[11\]](#), +IPR, +ICF, +IFC, &K, \Q, +UPSV, +CMUX, +USIO, +UUARTCONF AT commands where supported.

-  The **DSR** and **DCD** pins of LENA-R8 modules toggle as output for ~600 ms during module's boot. The **DSR** and **DCD** pins are also set as output during the firmware update over the USB interface.

Auxiliary UART interface

LARA-R202, LARA-R203 and LARA-R211 modules provide an auxiliary 2-wire 1.8 V UART interface, as alternative function of the I2C interface (**SCL** and **SDA** pins) including:

- data lines (**SCL** pin as AUX UART data output, **SDA** pin as AUX UART data input)

LARA-R6 and LARA-L6 series modules provide an auxiliary 4-wire 1.8 V UART interface, as alternative function of the main UART interface **DTR**, **DSR**, **DCD** and **RI** pins, including:

- data lines (**DCD** pin as AUX UART data output, **DTR** pin as AUX UART data input)
- HW flow control lines (**RI** as AUX UART flow control output, **DSR** as AUX UART flow control input)

The support of the auxiliary UART as alternative function of the main UART interface **DTR**, **DSR**, **DCD** and **RI** pins is not presented with the "00C" version of LENA-R8 modules.

The data lines of the auxiliary UART interfaces of the modules are electrically compatible, so that the same compatible external circuit can be used. However, for the main UART interface, we recommend checking possible differences in the strength of the internal pull-ups at the inputs of the modules in case open-drain drivers or voltage dividers are used in the external circuit. We recommend using unidirectional push-pull drivers, and to use the **V_INT** output to supply the module side of external voltage translators connected to the UART interfaces of the cellular modules.

Note that the AUX UART is available on different pins of LARA-R2 modules as compared with the LARA-R6 and LARA-L6 cellular modules, as described above.

The functions, baud rates and configurations available and supported by the modules for the auxiliary UART interface may slightly differ: see the related module's data sheet [\[1\]](#) [\[4\]](#) [\[5\]](#) [\[7\]](#) and the related AT commands manual [\[9\]](#) [\[10\]](#) [\[11\]](#), +IPR, +ICF, +IFC, &K, \Q, +USIO, +UUARTCONF AT commands.

2.3.8 USB interface

LARA and LENA cellular modules provide a compatible USB 2.0 High-Speed interface including:

- the same **VUSB_DET** input pin to detect the presence of an external USB host and enable the USB interface of the module by applying an external valid USB VBUS voltage. See the related module's data sheet [\[1\]](#) [\[4\]](#) [\[5\]](#) [\[7\]](#) for the valid voltage range.
- the same **USB_D+** and **USB_D-** data and signaling lines according to the USB 2.0 standard.

The USB interface supports AT commands and data communication, GNSS tunneling, the FW update by FOAT or the u-blox EasyFlash tool, and the diagnostic trace logging functions on all the LARA and LENA cellular modules.

The configurations available and supported by LARA-R2, LARA-R6, LARA-L6 and LENA-R8 cellular modules for the USB interface may slightly differ: see the related module's data sheet [1] [4] [5] [7], the related system integration manual [2] [6] [8], and the related AT commands manual [9] [10] [11], +USIO, +UUSBCONF AT commands, where supported.

-  The USB interface of LARA-R6 and LARA-L6 is enabled only if an external voltage detectable as High logic level is present at the **VUSB_DET** input during the module's switch-on boot sequence. This configuration can be changed by the +UUSBDET AT command on all LARA-R6 and LARA-L6 modules versions except the "00B" product version of LARA-R6001D modules.

The LENA-R8 series cellular modules include the **USB_BOOT** input, which must be set at the 1.8 V voltage level of the **V_INT** supply output to enable the FW update by the dedicated tool over the USB interface of the modules' cellular system.

-  We highly recommend providing accessible test points on the **VUSB_DET**, **USB_D+**, **USB_D-** and **USB_BOOT** pins of LARA and LENA cellular modules, for FW update and diagnostic.

2.3.9 I2C interface

LARA-R2, LARA-R6, LARA-L6 and LENA-R8001 cellular modules provide a 1.8 V I2C interface (over the same **SDA**, **SCL** pins) to communicate with external compatible u-blox GNSS chips / modules.

LARA-R2, LARA-R6 and LARA-L6 modules supports also I2C communication with any external compatible I2C devices. as for example an audio codec.

The support of the cellular I2C interface over **SDA** and **SCL** pins is not presented with the "00C" product version of the LENA-R8001M10 modules.

LARA-R2 modules do not integrate pull-up resistors on **SDA** and **SCL** lines: if the I2C interface is used, external pull-up resistors must be provided. Instead, LARA-R6 and LARA-L6 series modules have internal pull-up resistors on **SDA** and **SCL** lines, therefore external pull-up resistors are not necessary. LENA-R8 cellular modules have weak active internal pull-ups on **SDA** and **SCL** lines, so it may be necessary to add external pull-up resistors, depending on the characteristics of the application.

We recommend using the **V_INT** output to supply the module side of external voltage translators connected to the I2C interface.

2.3.10 Digital audio interface

LARA-R202, LARA-R203, LARA-R211, LARA-R280, LARA-R281, LARA-R6001, LARA-R6401, and LARA-R6801 data and voice cellular modules provide an electrical compatible 1.8 V digital audio interface over the same **I2S_TXD**, **I2S_RXD**, **I2S_CLK**, **I2S_WA** pins, to transfer digital audio data to and from an external device as an audio codec.

The support of the cellular I2S digital audio interface function over **I2S_TXD**, **I2S_RXD**, **I2S_CLK** and **I2S_WA** pins is not presented with the "00C" product version of LENA-R8 series modules.

LARA-R204, LARA-R220, LARA-R6001D, LARA-R6401D and LARA-L6004D data-only products do not support voice / audio feature.

The configurations available and supported by the modules for the digital audio interface may slightly differ: see the related module's data sheet [1] [4] [5] [7], integration manual [2] [6] [8], and AT commands manual [9] [10] [11] (+UI2S AT command, where supported).

2.3.11 Clock output

LARA-R202, LARA-R203, LARA-R211, LARA-R280, LARA-R281, LARA-R6001, LARA-R6401, and LARA-R6801 data and voice cellular modules provide an electrical compatible 1.8 V digital clock output on the same **GPIO6** pin, mainly designed to feed the clock input of an external audio codec.

LARA-R204, LARA-R220, LARA-R6001D, LARA-R6401D and LARA-L6004D data-only products and LENA-R8 modules do not support clock output over the **GPIO6** pin.

The support of the cellular clock output functionality over the **GPIO6** pin is not presented with the “00C” product version of LENA-R8 modules.

2.3.12 GPIOs

LARA-R2, LARA-R6 and LARA-L6 cellular modules provide nine 1.8 V GPIO pins (**GPIO1-GPIO5**, **I2S_TXD**, **I2S_RXD**, **I2S_CLK**, **I2S_WA**), while LENA-R8 cellular modules provide six 1.8 V GPIO pins (**GPIO1-GPIO6**), electrically compatible, that can be configured as General-Purpose Input/Output or to provide dedicated functions. For further details, see the related module’s data sheet [1] [4] [5] [7], and the GPIO chapter in the related AT commands manual [9] [10] [11], +UGPIOC AT command.

2.3.13 Antenna dynamic tuning

LARA-R6401 and LARA-R6401D modules, and any LARA-R6 and LARA-L6 modules “01B” product version include two 1.8 V digital pins (**RFCTL1** pin #97 and **RFCTL2** pin #98) that can be configured to change their output value in real time according to the operating LTE band in use.

These pins, paired with an external antenna tuner IC or RF switch, can be used to:

- tune antenna impedance to reduce power losses due to mismatch
- tune antenna aperture to improve total antenna radiation efficiency
- select the optimal antenna for each operating band

The functionality of the same **RFCTL1** and **RFCTL2** pins is not supported by LARA-R8 modules.

LARA-R2 modules have **RSVD** pins #97 and #98 with no functionality on the same spaces.

2.3.14 Reserved pins

LARA and LENA cellular modules include pins reserved for future use, marked as **RSVD**, which can all be left unconnected on the application board, except the **RSVD #33** pin:

- we recommend connecting to ground the **RSVD #33** pin of LARA-R2 modules
- we suggest connecting an accessible test point to the **RSVD #33** pin of LARA-R6 / LARA-L6

The same pin #33 has the **USB_BOOT** function on LENA-R8 cellular modules: the line must be set at the 1.8 V voltage level of the **V_INT** supply output to enable the FW update over cellular USB interface. We recommend making this pin accessible accordingly.

2.3.15 GNSS interfaces

LENA-R8001M10 modules include a GNSS system based on the u-blox M10 standard precision concurrent GNSS receiver, which can be operated fully independently from the cellular system. The GNSS system has dedicated interfaces available on pins that are not in use on the other LARA / LENA modules:

- the **ANT_GNSS** RF input is a **RSVD** pin, internally not connected on other LARA / LENA
- the **VCC_GNSS** and **VBCKP_GNSS** supply inputs are **RSVD** pins, not is use on other LARA / LENA
- the **TXD_GNSS** UART data output, **RXD_GNSS** UART data input, **TIMEPULSE** output and **EXTINT** input are SDIO pins, not is use on LARA-R2, or **RSVD** pins, not is use on other LARA / LENA

2.3.16 Other considerations and test points

Table 8 lists the interfaces for special purposes, including firmware update by dedicated tool and diagnostic by u-blox m-center tool, on LARA / LENA modules.

Module	FW update by dedicated tool	Diagnostic by dedicated tool
LARA-R2	USB UART (2-wire data input/output) by EasyFlash tool	USB UART (2-wire data input/output) AUX UART (2-wire data input/output) HSIC
LARA-R6 LARA-L6	USB by EasyFlash tool	USB
LENA-R8	USB + USB_BOOT by ResearchDownload tool	USB

Table 8: Interfaces for FW update and diagnostic on LARA / LENA modules

It is highly recommended to provide test points directly connected to the pins with FW update and/or diagnostic functions available (in particular the **VUSB_DET**, **USB_D+**, **USB_D-** and **USB_BOOT** pins), depending also on which interface of the module is connected to external host application processor (as the **RXD** and **TXD** lines of the UART interface also have to be considered).

Additionally, it is recommended to provide test points directly connected to the following pins of the modules for diagnostic purposes:

- **V_INT**
- **PWR_ON**
- **RESET_N**
- **RSVD #33** of LARA-R6 / LARA-L6 modules
- **USB_BOOT** of LENA-R8 modules
- **TXD_GNSS** and **RXD_GNSS** of LENA-R8001M10 modules

All GND pins of LARA and LENA modules are intended to be externally connected to ground.

 For additional specific design-in guidelines, see the modules' system integration manual [\[2\]](#)[\[6\]](#)[\[8\]](#).

2.4 Schematic for LARA and LENA modules integration

Figure 7 illustrates an example of a schematic diagram where a LARA-R2, a LARA-R6, a LARA-L6, or a LENA-R8 series module is integrated into the same application board, using almost all the available interfaces and functions of the modules. The different mounting options for the external parts are noted according to the functions supported by each module.

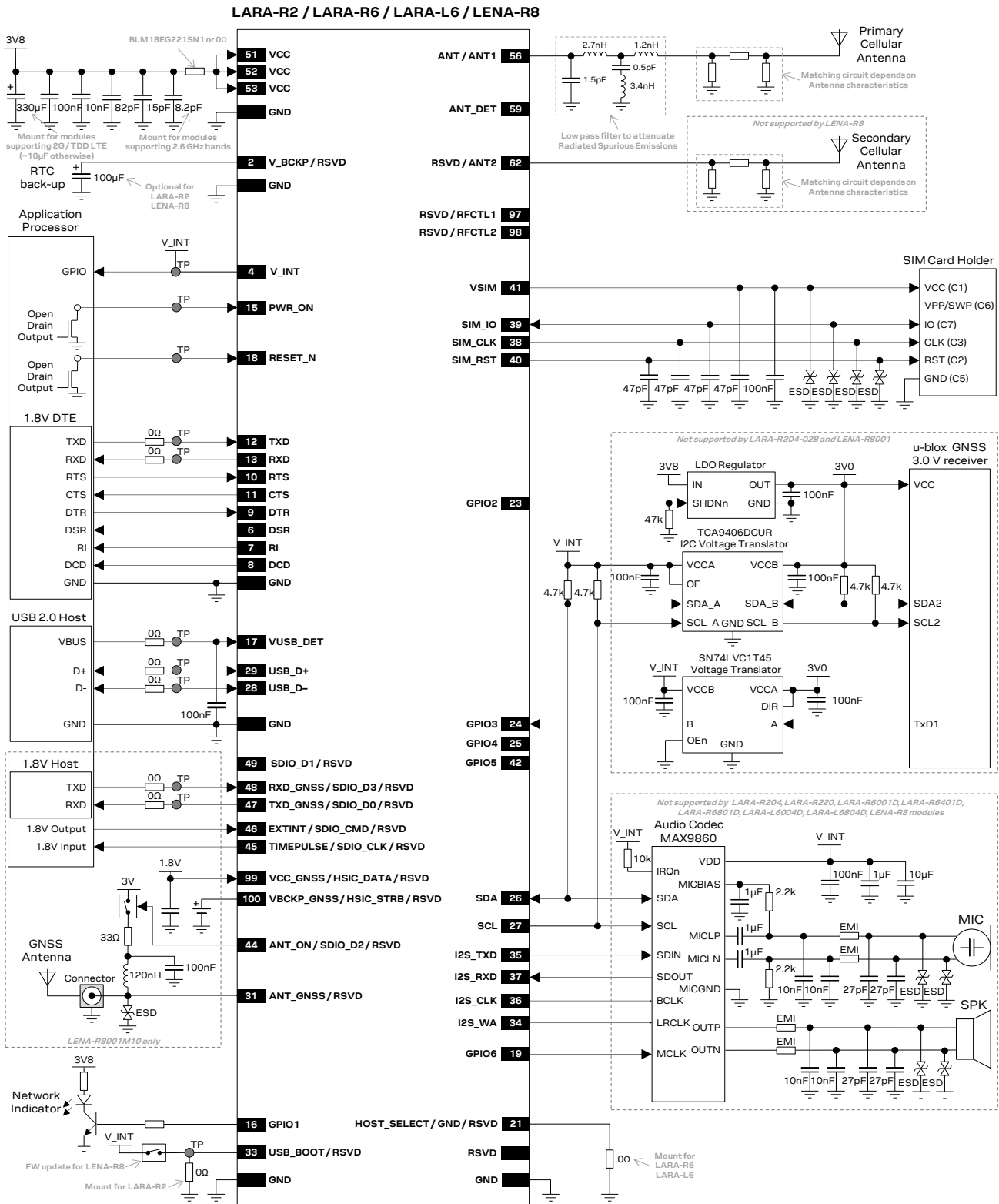

Figure 7: Illustrative example of schematic diagram to integrate LARA / LENA modules on the same application board

Appendix

A Glossary

Abbreviation	Definition
2G	2nd Generation Cellular Technology (GSM, GPRS, EGPRS)
3G	3rd Generation Cellular Technology (UMTS, HSDPA, HSUPA)
3GPP	3rd Generation Partnership Project
8-PSK	8 Phase-Shift Keying modulation
APAC	Asia-Pacific
AT	AT Command Interpreter Software Subsystem, or attention
AUX	Auxiliary
BB	Baseband
Cat	Category
CDMA	Code Division Multiple Access
CS	Coding Scheme
CSFB	Circuit-Switched-Fall-Back
CTS	Clear To Send
DARP	Downlink Advanced Receiver Performance
DCD	Data Carrier Detect
DCS	Digital Cellular System
DL	Down-Link (Reception)
DNI	Do Not Install
DSR	Data Set Ready
DTLS	Datagram Transport Layer Security
DTR	Data Terminal Ready
EDGE	Enhanced Data rates for GSM Evolution (EGPRS)
eDRX	Extended Discontinuous Reception
EGPRS	Enhanced General Packet Radio Service (EDGE)
E-GSM	Extended GSM
EMEA	Europe, the Middle East and Africa
EMI	Electro-Magnetic Interference
ESD	Electro-Static Discharge
E-UTRA	Evolved Universal Terrestrial Radio Access
FDD	Frequency Division Duplex
FOAT	Firmware update Over AT commands
FOTA	Firmware update Over The Air
FTPS	File Transfer Protocol Secure
FW	Firmware
GMSK	Gaussian Minimum-Shift Keying modulation
GND	Ground
GNSS	Global Navigation Satellite System
GPIO	General-Purpose Input/Output
GPRS	General Packet Radio Service
GPS	Global Positioning System
GSM	Global System for Mobile communication

Abbreviation	Definition
HSDPA	High Speed Downlink Packet Access
HSIC	High-Speed Inter-Chip USB interface
HSPA	High-Speed Packet Access
HSUPA	High Speed Uplink Packet Access
HTTPS	HyperText Transfer Protocol Secure
I/O	Input/Output
I2C	Inter-Integrated Circuit interface
I2S	Inter IC Sound interface
IP	Internet Protocol
LED	Light Emitting Diode
LGA	Land Grid Array
LPWA	Low Power Wide Area
LTE	Long Term Evolution
LwM2M	Open Mobile Alliance Lightweight Machine-to-Machine protocol
MQTT	Message Queuing Telemetry Transport
PA	Power Amplifier
PCS	Personal Communications Service
PIO	Peripheral Input/Output
PMU	Power Management Unit
PSM	Power Saving Mode
N.A.	Not Available / Not Applicable
RAT	Radio Access Technology
RF	Radio Frequency
RI	Ring Indication
Rx	Receiver
RTC	Real Time Clock
RTS	Request To Send
SAW	Surface Acoustic Wave
SDIO	Secure Digital Input Output
SIM	Subscriber Identification Module
SMS	Short Message Service
SPI	Serial Peripheral Interface
TCP	Transmission Control Protocol
TDD	Time Division Duplex
TDMA	Time Division Multiple Access
TLS	Transport Layer Security
TP	Test Point
Tx	Transmitter
UART	Universal Asynchronous Receiver-Transmitter
UDP	User Datagram Protocol
uFOTA	u-blox Firmware update Over The Air
UL	Up-Link (Transmission)
UMTS	Universal Mobile Telecommunications System
USB	Universal Serial Bus
VoLTE	Voice over LTE

Related documentation

- [1] u-blox LARA-R2 series data sheet, [UBX-16005783](#)
- [2] u-blox LARA-R2 series system integration manual, [UBX-16010573](#)
- [3] u-blox nested design application note, [UBX-16007243](#)
- [4] u-blox LARA-R6 series data sheet, [UBX-21004391](#)
- [5] u-blox LARA-L6 series data sheet, [UBX-21047783](#)
- [6] u-blox LARA-R6 / LARA-L6 series system integration manual, [UBX-21010011](#)
- [7] u-blox LENA-R8 series data sheet, [UBX-22003110](#)
- [8] u-blox LENA-R8 series system integration manual, [UBX-22015376](#)
- [9] u-blox AT commands manual, [UBX-13002752](#)
- [10] u-blox LARA-R6 / LARA-L6 series AT commands manual, [UBX-21046719](#)
- [11] u-blox LENA-R8 series AT commands manual, [UBX-22016905](#)

 For regular updates to u-blox documentation and to receive product change notifications, register on our homepage (www.u-blox.com).

Revision history

Revision	Date	Name	Comments
R01	29-Apr-2021	sses	Initial release
R02	05-May-2022	psca / sses	Added LARA-R6001D and LARA-R6401D. Some corrections and clarifications.
R03	08-Aug-2022	sses	Added LARA-L6004, LARA-L6004D, LENA-R8001 and LENA-R8001M10. Some corrections and clarifications.
R04	15-May-2023	sses	Added LARA-R6801D, LARA-L6804D, and any other LARA-R6 and LARA-L6 modules "01B" product version. Revised HSUPA category for LARA-L6 modules. Revised futures available or planned (auxiliary UART, I2C, I2S, clock output, PSM, eDRX, SIM detection, Antenna dynamic tuning), remarked VoLTE and CSFB support, and behavior of DSR / DCD pins at boot for LENA-R8 modules. Minor corrections and clarifications.
R05	10-Oct-2023	sses	Added low-pass filter in RF transmitting antenna application circuit. Clarified LENA-R8 modules one-shot automatic baud rate detection behavior. Minor corrections and clarifications.

Contact

u-blox AG

Address: Zürcherstrasse 68
8800 Thalwil
Switzerland

For further support and contact information, visit us at www.u-blox.com/support.