

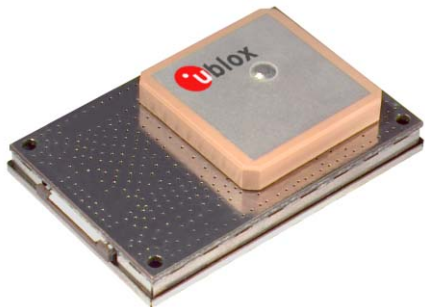

SAM

GPS Smart Antenna Module SiRFstar™ II Positioning Engine

SAM is a high-performance GPS receiver with integrated antenna embedded in a compact package. SAM allows the integration of GPS technology into a broad spectrum of mobile products with minimal design effort and time. The integrated data logger allows storing GPS data on the receiver.



Overview

The SAM smart antenna module is a complete GPS receiver with an integrated ceramic patch GPS antenna. This assembly combines simple and accelerated system integration with excellent GPS performance and accuracy. This makes it the ideal product for integration into handheld devices and into smart antenna products.

Based on the u-blox TIM GPS receiver macro-component the SAM smart antenna module provides excellent GPS performance within very small profile.

SAM provides two serial ports, which can handle NMEA or SiRF® proprietary data format or accept differential GPS data (RTCM). The integrated datalogging function stores up to 100'000 logs on the internal FLASH memory.

Operating at a nominal operating voltage of 3.3 Volts, the SAM consumes less than 0.5 Watts in continuous operation mode. The implementation of the TricklePower™ mode allows a considerable reduction of power consumption for applications where power consumption is of primary concern.

Benefits

- Integrated GPS receiver with patch antenna
- Low power consumption
- Excellent GPS performance
 - Fast time-to-first-fix
- Simple and effortless system integration for accelerated time-to-market and optimal system solution
- Supports versatile mounting techniques
 - Screw-mount
 - Snap-in
 - Soldering
- Flexible flat cable connector
- Satellite Based Augmentation Systems (SBAS)
- Integrated data logging
- Fully EMI shielded
- Immune to RF interference

Features

- 12 channel GPS receiver
- 1 Hz position update rate
- SiRFstar™ II architecture
 - GRF2i RF front-end IC
 - GSP2e GPS DSP with integrated Real Time Clock
- 8 MBit FLASH memory
- Low-noise amplifier
- Power management features
 - TricklePower™ mode
 - Push-to-Fix™ mode
- Operating voltage 2.75 ... 3.45 V
- Battery voltage supply pin for internal backup memory and real time clock
- Industrial operating temperature range -40...85°C
- Small size
 - Size 31.5 mm x 47 mm
 - Height 9.5 mm
 - Weight 23 g

Support Products

SAM Evaluation Kit

Use the SAM Evaluation Kit to experience the power of SAM.

*your position
is our focus*



Specifications

Receiver Performance Data

Receiver Type	12 channel, L1 frequency, C/A code
Max. Update Rate	1 Hz
Accuracy	Position 4 m CEP DGPS 2 m CEP ¹
Start-up Times	Hot start 2-8 s Warm start 38 s Cold start 45 s

Signal reacquisition	100 ms
Dynamics	< 4 g
Operational Limits	COCOM restrictions apply

¹ Depending on accuracy of correction data

For more detailed information on the GPS performance check the *SAM Data Sheet*.

Electrical Data

Power Supply	2.75 – 3.45 V
Power Consumption	< 160 mA (continuous)
Power Save Modes	10 mA (8s update rate) 50 mA (1s update rate)
Backup Power	1.85 V – 3.6 V, 4.5 μ A
Serial Ports	Two UARTS @ 3.3 V levels (CMOS / TTL compatible)
Protocols	NMEA, SiRF [®] binary, RTCM
Interface	20 pin, Flex Cable Connector 0.50mm (.020") Pitch, Bottom Configuration

Datalogger

Capacity	Max. 100K position logs
Logged Parameters	Position, velocity, time, GPS status
Configuration	Serial protocol messages
Download	Compressed format, serial
Logging Events	Time intervals, distance

Environmental Data

Operating Temperature	-40°C to 85°C
Storage Temperature	-40°C to 125°C

Mechanical Data

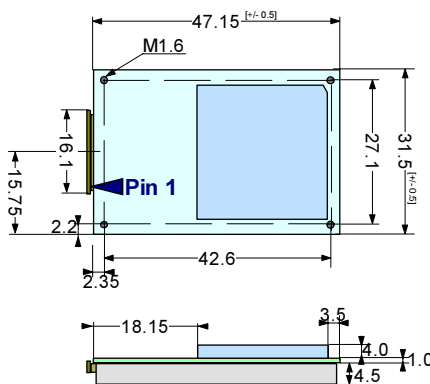

All Dimension are in mm.
 All Tolerances +/- 0.2mm, if not indicated differently.

Ordering Information

SAM-ST-0-000-0	SAM GPS Smart Antenna Module Single units
SAM-ST-0-000-2	SAM GPS Smart Antenna Module Packing unit, 200 pieces
SEK-ST-0-000-0	SAM Evaluation Kit
SAB-ST-0-000-0	SAM Adapter Kit to connect SAM to TIM Evaluation Kit

Parts of this product are patent protected.

The specifications in this document are subject to change at u-blox' discretion. u-blox assumes no responsibility for any claims or damages arising out of the use of this document, or from the use of modules based on this document, including but not limited to claims or damages based on infringement of patents, copyrights or other intellectual property rights. u-blox makes no warranties, either expressed or implied with respect to the information and specifications contained in this document. u-blox does not support any applications in connection with active weapon systems and ammunition, nor life supporting applications. Performance characteristics listed in this document are estimates only and do not constitute a warranty or guarantee of product performance. The copying, distribution and utilization of this document as well as the communication of its contents to others without expressed authorization is prohibited. Offenders will be held liable for the payment of damages. All rights reserved, in particular the right to carry out patent, utility model and ornamental design registrations.

u-blox, the u-blox logo and ANTARIS are registered trademarks of u-blox AG. NavLox, FixNOW and EKf are trademarks of u-blox AG.
 Other trademarks are property of the respective companies. Copyright © 2003, u-blox AG