

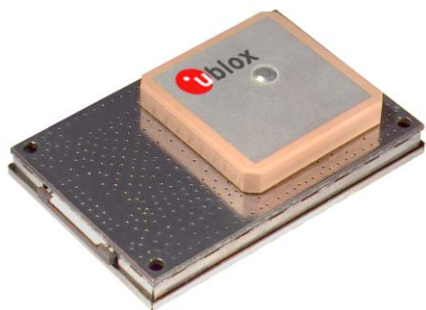

SAM-LS

Programmable GPS Smart Antenna ANTARIS® Positioning Engine

The smart antenna SAM-LS combines an ultra-low power GPS receiver module with an integrated patch antenna. The form factor and interfaces are compatible to its predecessor SAM. It provides two 3V serial ports accessible through a connector for flexible flat cables. This all-in-one solution is best suited for a broad spectrum of end products where very fast and straightforward system integration at minimum development costs and risks is a major issue.



Overview

The leading ANTARIS® GPS Engine provides excellent navigation performance under dynamic conditions in areas with limited sky view like urban canyons, high sensitivity for weak signal operation without compromising accuracy, and support of DGPS and multiple SBAS systems like WAAS and EGNOS. The 16 parallel channels and 8192 search bins provide fast start-up times. The low power consumption and FixNow™ power saving mode make this product suitable for handheld and battery-operated devices.

The SAM-LS provides versatile mounting techniques which include screwing, soldering, gluing and press-fit. Mounting the SAM-LS into a location with good view to satellites, applying power and connecting serial interfaces are the only steps to commission the GPS receiver.

Benefits

- All-in-one GPS receiver with patch antenna
- High acquisition and tracking sensitivity
- Ultra-low power consumption
- Excellent GPS performance
 - Excellent navigation accuracy even at low signal levels
 - Active multipath detection and removal
 - Fast Time-to-first-fix (TTFF)
- Versatile mounting techniques
 - Screw-mount, snap-in, soldering, press-fit
 - Allows simple and effortless integration with little time, low cost and minimum design risks
- Maximum flexibility
 - Extensively configurable
- Fully EMI shielded

Features

- 16 channel GPS receiver
- 8192 simultaneous time-frequency search bins
- 4 Hz position update rate
- Based on the ANTARIS GPS Technology
 - ATR0600 RF front-end IC
 - ATR0620 Baseband IC with ARM7TDMI inside
 - ATR0610 Low noise amplifier IC
- FLASH memory
- DGPS and SBAS (WAAS, EGNOS) support
- FixNow™ power saving mode
- Operating voltage 2.7...3.3 V
- Battery voltage supply pin for internal backup memory and real time clock
- Industrial operating temperature range -40...85°C
- Small size: 31.5 x 47 x 9.5 mm, weight: 23g

Support Products

ANTARIS EvalKit

Use the ANTARIS EvalKit to experience the power of SAM-LS.

*your position
is our focus*



Specifications

Receiver Performance Data

| | |
|-----------------------------|--|
| Receiver Type | 16 channel, L1 frequency, C/A code |
| Max. Update Rate | 4 Hz |
| Accuracy | Position 2.5 m CEP DGPS / SBAS 2.0 m CEP ¹ |
| Start-up Times | Hot start <3.5 sec Warm start 33 sec Cold start 34 sec |
| Signal reacquisition | < 1 s |
| Dynamics | < 4 g |
| Operational Limits | COCOM restrictions apply |

¹ Depends on accuracy of correction data of DGPS or SBAS service

Electrical Data

| | |
|--------------------------|--|
| Power Supply | 2.7 – 3.3 V |
| Power Consumption | typ. 168 mW @ 3.0 V typ. 151 mW @ 2.7 V Sleep mode: typ. 2000 µA |
| Backup Power | 1.95 V – 3.6 V |
| Serial Ports | Two UARTs @ 3 V levels |
| Protocols | NMEA, UBX binary, RTCM Interleaving multiple protocols via same serial interface is supported |
| Interface | 20 pin, Flex Cable Connector 0.50mm (.020") Pitch, Bottom Configuration |

Environmental Data

| | |
|------------------------------|----------------|
| Operating Temperature | -40°C to 85°C |
| Storage Temperature | -40°C to 125°C |

Mechanical Data

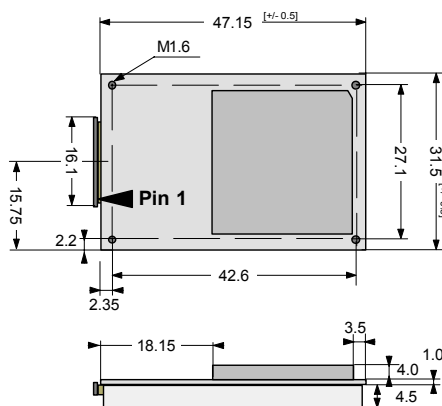

All Dimension are in mm.
 All Tolerances +/- 0.2mm, if not indicated differently.

Ordering Information

| | |
|-----------------------|--|
| SAM-LS-0-000-0 | SAM-LS – Programmable GPS Smart Antenna Delivery Packing 0 = Single samples 2 = Packing unit (200 pieces) |
| AEK-LS-0-000-0 | ANTARIS EvalKit - Evaluation Kit |
| SAB-ST-0-000-0 | Accessory: SAM Adapter Board with Flat Flex Cable for easy interfacing |

Parts of this product are patent protected.